

AIR CONDITIONER
Wall mounted type

DESIGN & TECHNICAL MANUAL

For Extra Cold Climate Area

INDOOR



UIWH30AVFJ

OUTDOOR



UOSH30AHXHJ

Notices:

- Product specifications and design are subject to change without notice for future improvement.
- For further details, please check with our authorized dealer.

CONTENTS

Part 1. INDOOR UNIT	1
1. Product features	2
1-1. Model lineup	2
1-2. Features	2
1-3. Details of server room control	4
2. Remote controller	8
2-1. Wireless remote controller	8
3. Specifications	12
4. Dimensions	14
4-1. Model: UIWH30AVFJ	14
5. Wiring diagrams	16
5-1. Model: UIWH30AVFJ	16
6. Capacity table	17
6-1. Cooling capacity	17
6-2. Heating capacity	18
7. Fan performance	19
7-1. Air velocity distributions	19
7-2. Airflow	21
8. Operation noise (sound pressure)	22
8-1. Noise level curve	22
8-2. Sound level check point	23
9. Safety devices	24
10. External input and output	25
10-1.External input	25
10-2.External output	27
10-3.Combination of external input and output	29
10-4.Details of function	31
11. Function settings	47
11-1.Function settings by using remote controller	47
11-2.Custom code setting for wireless remote controller	54
12. Accessories	55
13. Optional parts	56
13-1.Controllers	56
13-2.Others	57

CONTENTS (continued)

Part 2. OUTDOOR UNIT 59

1. Specifications	60
2. Dimensions	61
2-1. Model: UOSH30AHXHJ	61
3. Installation space	62
3-1. Model: UOSH30AHXHJ	62
4. Refrigerant circuit	65
4-1. Model: UOSH30AHXHJ	65
5. Wiring diagrams	66
5-1. Model: UOSH30AHXHJ	66
6. Capacity compensation rate for pipe length and height difference ..	67
6-1. Model: UOSH30AHXHJ.....	67
7. Additional charge calculation	68
7-1. Model: UOSH30AHXHJ	68
8. Airflow	69
8-1. Model: UOSH30AHXHJ	69
9. Operation noise (sound pressure)	70
9-1. Noise level curve	70
9-2. Sound level check point	71
10. Electrical characteristics	72
11. Safety devices	73
12. External input and output	74
12-1.External input	74
12-2.External output	76
13. Function settings	78
13-1.Local setting switch buttons	78
13-2.Local setting procedure	80
14. Accessories	84
15. Optional parts	85

Part 1. INDOOR UNIT

**WALL MOUNTED TYPE:
UIWH30AVFJ**

1. Product features

Implemented core technology provides easy-to-use product operations that realize a comfortable space.

1-1. Model lineup



UIWH30AVFJ



UOSH30AHXHJ

1-2. Features

■ High energy performance

		MODEL
		UIWH30AVFJ
Seasonal Energy Efficiency Ratio (SEER)	Btu/hW	18.7
Heating Seasonal Performance Factor (HSPF)		11.8
Coefficient Of Performance (COP)		11.7
Energy Efficiency Ratio (EER)		12.5

*Measurement conditions: ANSI/ASHRAE Standard 37-1988

■ Powerful heating operation and high performance heating

These systems can deliver 100% of rated heating capacity at 5°F (-15°C) and operate down to -15°F (-26°C), so stay more comfortable at low ambient temperature than previous.

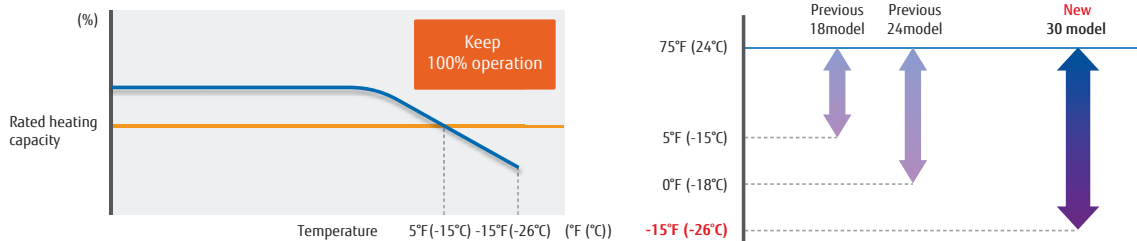

■ Base heater

- Equipped with a base heater that provides powerful heating even at extra low outdoor temperature. (Prevents the exhaust water from freezing.)
- The cultivated base design discharges the melted water out of many water discharge holes.

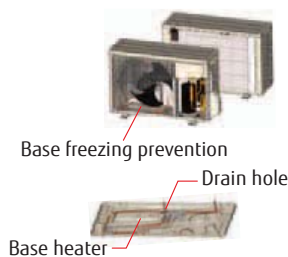

Without base heater



With base heater

■ Set temperature control by 1 °F possible

Temperature setting by 1 degree in Fahrenheit or by 0.5 degree in Celsius possible.

■ Energy saving control by using human sensor

Implemented human sensor detects the presence or absence of human in a room by sensing movement of occupants, and suppress both of the air conditioner operation and energy consumption.

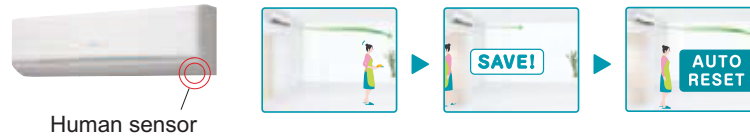

■ Corresponding to server room air conditioning

Cooling operation can be performed even in the low outdoor temperature and low humidity environment. In addition, the following interlock operation is possible by connecting 2 indoor units with a cable.

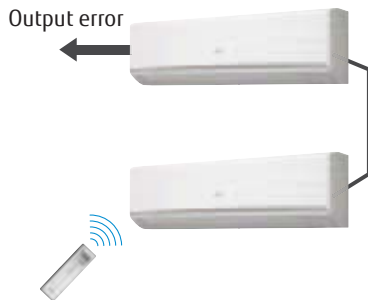

- Alternative operation: 2 units operate alternately.
- Backup operation: In case one unit breaks down, the other unit starts operation automatically.
- Supporting operation: Both units operate simultaneously when the loaded capacity is not enough with one unit.
- Server room control can be set at site.

1-3. Details of server room control

By activating server room control using function setting 96, this product maintains a room at constant temperature.

■ Available operations

When server room control is activated by changing the setting on function setting 96, this product maintains the room temperature constant by performing 3 types of operations automatically according to the room temperature conditions.

While this function is activated, contents of operation is fixed as follows:

Operation mode	Set temperature	Airflow mode
COOL	76°F (24°C)*	HIGH

*: Set temperature correction ($\pm 8^{\circ}\text{F}$ [4°C]) is possible by switching the setting value on function setting 30. For the setting details, refer to “Room temperature control for indoor unit sensor” in “Contents of function setting” on page 48.

- **Alternative operation**

Controls the units operations by using the weekly timer of the primary unit.

When the weekly timer is activated and the primary unit operation is turned off, the secondary unit starts operation simultaneously.

Also, when the weekly timer is activated and the primary unit operation is turned on, the secondary unit stops operation simultaneously.

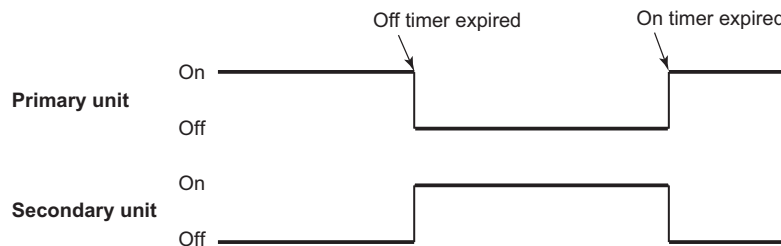

- **Backup operation**

Regardless of the primary-secondary relation of the unit, if an error occurred on one unit, operation start indication is issued to another unit and the unit starts backup operation.

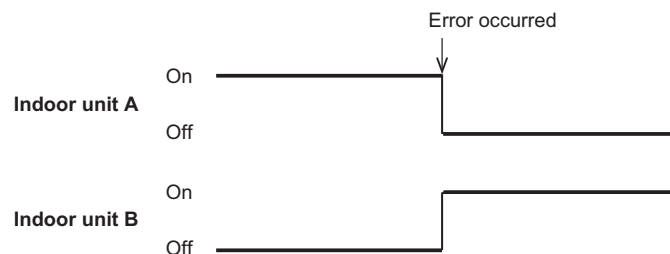

- **Supporting operation**

When the room temperature does not reach to the set point after a certain period of time, regardless of the primary-secondary relation of the unit, operation start indication is issued to another unit and both indoor units perform air conditioning simultaneously.

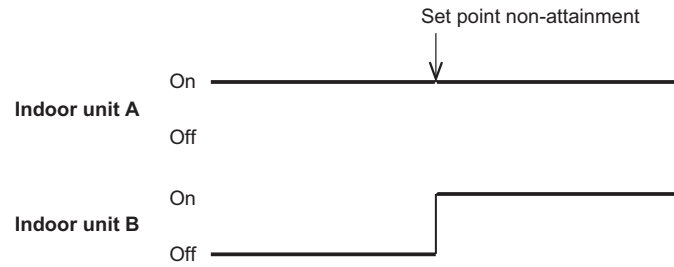

*: Operation is started even when the unit is stopped by the weekly timer.

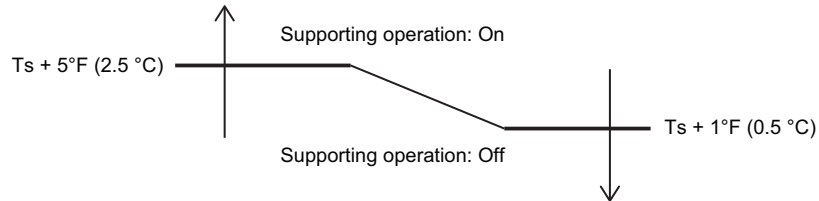

NOTE: While performing this function, following functions cannot be used:

- Operation modes other than cooling
- Airflow modes other than HIGH
- Temperature setting other than 76°F (24°C)
- POWERFUL mode
- MIN. HEAT operation
- ECONOMY operation
- On/off timer, program timer, and SLEEP timer
- Weekly timer on secondary unit
- Human sensor function
- Shutdown operation
- Starting operation on secondary unit

To stop the operation, shutdown the power supply.

■ Precautions on unit installation

⚠ CAUTION

- Do not place any other electrical products or household belongings under the product. Condensation dripping from the product might get them wet, and may cause damage or malfunction to the property.
- In units installation facing each other, the vertical airflow direction louver on each indoor unit should be set at a position from 3 to 6.

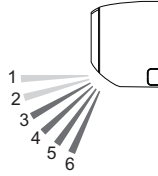

- Do not connect any wired remote controller.
-

To perform server room control, mind the followings:

- Additional cable connecting between 2 indoor units needs to be purchased locally.
- DIP switch on the indoor unit main PC board needs to be switched to “3WIRE”.
- Setting of function setting 30 “Room temperature control for indoor unit sensor” on each indoor unit needs to be same. For contents of the function setting 30, refer to “Room temperature control for indoor unit sensor” in [“Contents of function setting”](#) on page 48.
- Setting change on function setting 96 required. For contents of the function setting 96, refer to “Server room control” in [“Contents of function setting”](#) on page 48.

■ Initial setup for server room control

● Function setting procedure

Before activating server room control, assignment of primary unit and secondary unit is required. Change the setting of function setting 96 as follows:

1. Turn on the power source of 2 indoor units.
2. Set one of the indoor unit as "Primary unit" (Setting value: 01) by function setting 96. (For contents of function setting 96, refer to "Server room control" in "Contents of function setting" on page 48.)
When performing the setting, operate the remote controller close to the signal receiver on the primary unit as possible so that the signal transmission is firmly received by the primary unit only.
3. Set the other unit as "Secondary unit" (Setting value: 02) by function setting 96.
When performing the setting, operate the remote controller close to the signal receiver on the secondary unit as possible so that the signal transmission is firmly received by the secondary unit only.
4. Turn off the power supply of the 2 indoor units.

● Starting units operation

After the setting change on function setting 96 is completed, do as follows:

1. After 30 seconds or more since the power source is turned off, turn of the power source of the secondary unit.
2. Turn on the power source of the primary unit.
3. Press the MANUAL AUTO button on the primary unit for more than 3 seconds.
You will hear a short beep, and the primary unit starts operation.

NOTE: While performing these steps, error indications will be lit on the unit. Nevertheless, continue the procedure.

● Starting server room control

Set the weekly timer on the primary unit.

Server room control is activated, and the unit will start the alternative operation.

NOTE: If the alternative operation does not start or error indications on the unit are still lit, reconfirm whether the settings on function setting 96 are set correctly, and perform the setup procedures from the beginning.

As for the display pattern of the error indications of the indoor unit, refer to the installation manual.

2. Remote controller

2-1. Wireless remote controller

■ Features



- Temperature setting by 1 °F or by 0.5 °C possible.
- 5-mode timer setup (on, off, weekly, program, and sleep) available.
NOTE: When performing server room control, only the weekly timer is effective.
- Easy operation.
- Easy to change custom code (max. 4 custom code).
- Can be used jointly with wired remote controllers.
NOTE: When performing server room control, wired remote controller cannot be connected.

● Simple function setting

Setting of the air conditioner selection function is performed by remote controller.

● Weekly timer

Weekly timer can be easily set by wireless remote controller.

On and off can be set up to 4 times in a day, and up to 28 times in a week.

● Program timer

The program timer operates the on and off timer once within a 24-hour period.

● Sleep timer

The sleep timer function automatically corrects the temperature thermostat setting according to the time setting to prevent excessive cooling and heating while sleeping.

Cooling operation/Dry operation

When the sleep timer is set, the set temperature automatically rises 2 °F (1 °C) every hour. The set temperature can rise up to a maximum of 4 °F (2 °C).

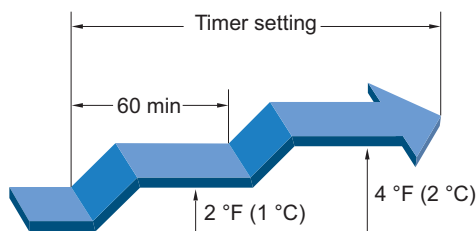

Heating operation

When the sleep timer is set, the set temperature automatically drops 2 °F (1 °C) every 30 minutes. The set temperature can drop to a maximum of 8 °F (4 °C).

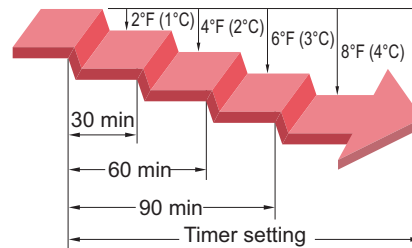

● Switching remote controller custom code

Code selector switch eliminates unit being wrongly switched. (Up to 4 codes can be set.)

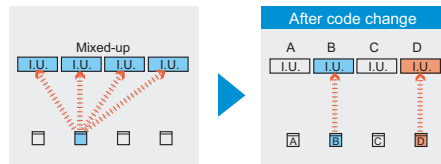

* I.U.: Indoor unit

● Temperature unit switchable

Easy to change the temperature unit between °F and °C by button operation.

Overview

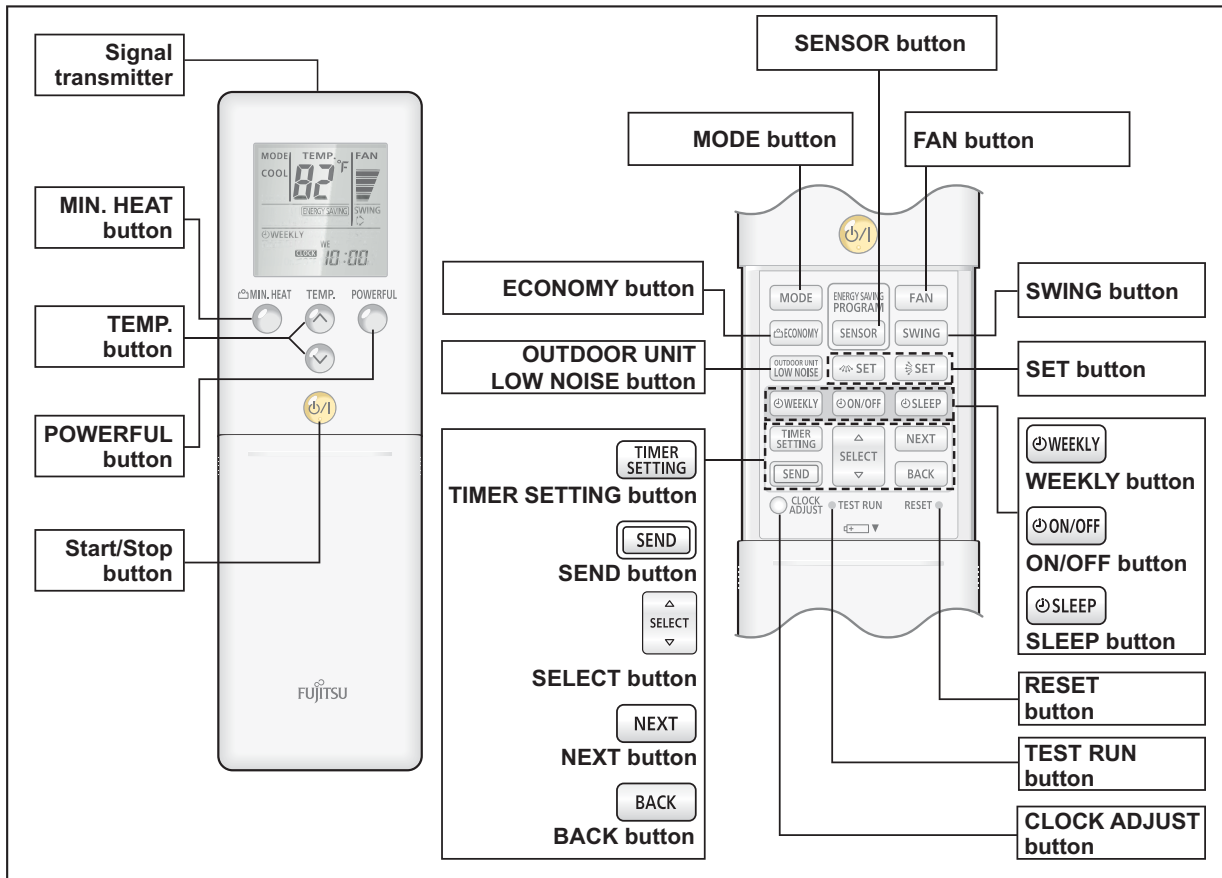

NOTE: Functions may differ by type of the indoor unit. For details, refer to the operation manual.

Display panel

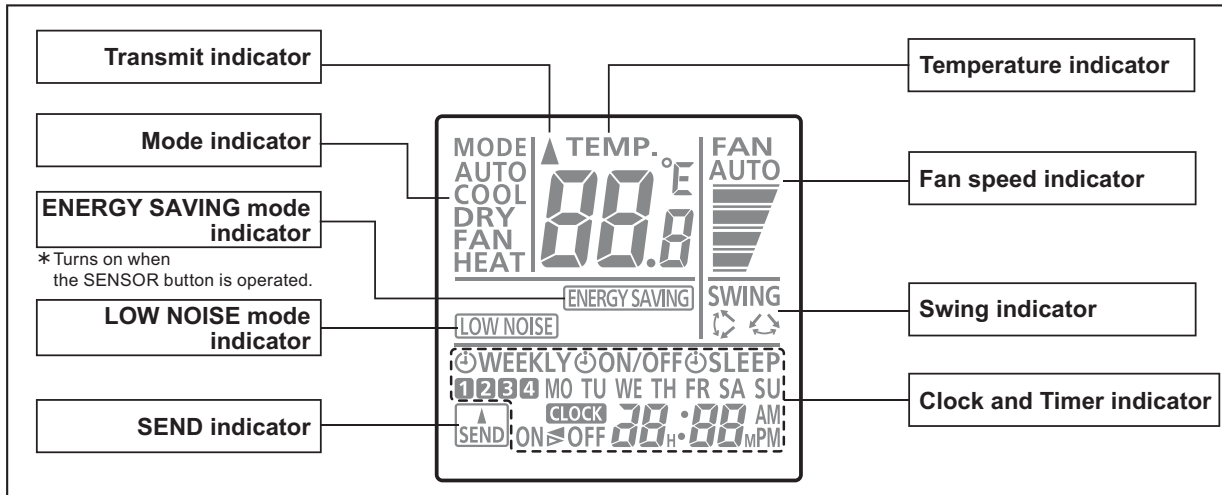

To facilitate explanation, the accompanying illustration has been drawn to show all possible indicators; in actual operation, however, the display will only show those indicators appropriate to the current operation.

■ Specifications

● Controller

Unit: in (mm)

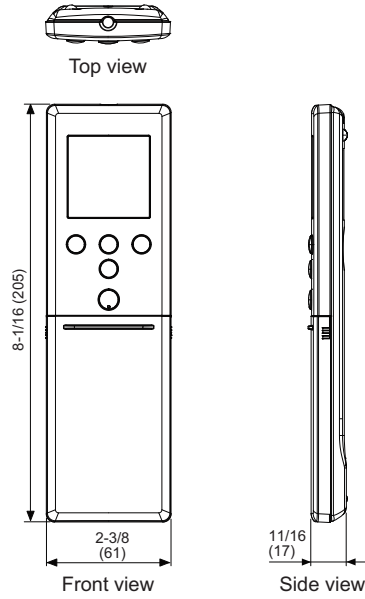

Size (H x W x D)	in (mm)	8-1/16 x 2-3/8 x 11/16 (205 x 61 x 17)
Weight	oz (g)	4.3 (122) (without batteries)

● Holder

Unit: in (mm)

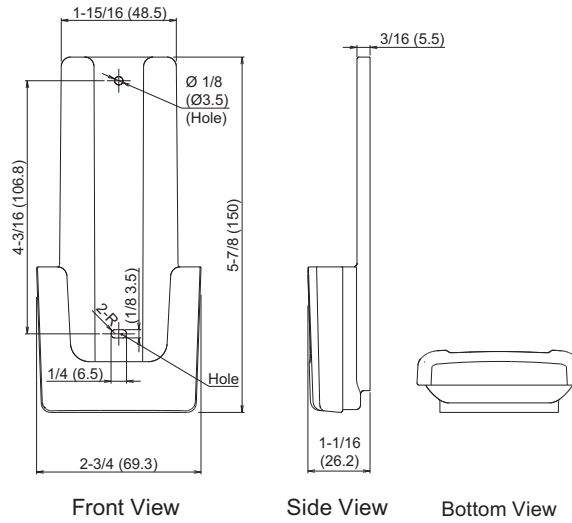

Size (H x W x D)	in (mm)	5-7/8 x 2-3/4 x 1-1/16 (150 x 69.3 x 26.2)
Weight	oz (g)	1 (27)

3. Specifications

Type				Wall mounted	
				Inverter heat pump	
Model name				UIWH30AVFJ	
Power supply				208/230 V ~ 60 Hz	
Available voltage range				187—253 V	
Capacity	Cooling	Rated	kW	8.79	
			Btu/h	30,000	
		Min.—Max.	kW	2.9—9.5	
				Btu/h	9,900—32,400
	Heating	Rated	kW	9.37	
			Btu/h	32,000	
Min.—Max.		kW	2.35—11.0		
			Btu/h	8,000—36,200	
Input power	Cooling	Rated	kW	2.40	
		Min.—Max.		0.58—3.83	
	Heating	Rated		2.74	
		Min.—Max.		0.50—4.28	
	Fan	HIGH	W	60	
		MED		35	
		LOW		20	
		QUIET		11	
Current	Cooling	Rated	A	10.6	
	Heating			12.0	
EER	Cooling	kW/kW	3.66		
		Btu/hW	12.5		
COP	Heating	kW/kW	3.42		
		Btu/hW	11.7		
SEER	Cooling	Btu/hW	18.7		
HSPF	Heating	Btu/hW	11.8		
Power factor	Cooling		%	99.6	
	Heating			99.2	
Moisture removal			pints/h (L/h)	9.7 (4.6)	
Maximum operating current *1	Cooling			20.5	
	Heating			20.5	
Fan	Airflow rate	Cooling	HIGH	CFM (m ³ /h)	812 (1,380)
			MED		665 (1,130)
			LOW		536 (910)
			QUIET		418 (710)
		Heating	HIGH		812 (1,380)
			MED		665 (1,130)
			LOW		536 (910)
			QUIET		418 (710)
	Type x Q'ty				Cross flow fan x 1
	Motor output		W		80
Sound pressure level *2	Cooling	HIGH	dB (A)	50	
		MED		45	
		LOW		38	
		QUIET		32	
	Heating	HIGH		49	
		MED		44	
		LOW		38	
		QUIET		32	
Heat exchanger type	Dimensions (H x W x D)		in (mm)	Main: 18-3/16 x 35-7/16 x 1-1/16 (462 x 900 x 26.6) Sub1: 4-15/16 x 35-7/16 x 17/32 (126 x 900 x 13.3) Sub2: 3-5/16 x 35-7/16 x 17/32 (84 x 900 x 13.3)	
	Fin pitch		FPI	1.2	
	Rows x Stages		Main: 2 x 22, Sub1: 1 x 6, Sub2: 1 x 4		
	Pipe type		Copper tube		
	Fin type		Aluminum		
Enclosure	Material		Polystyrene		
	Color		White Approximate color of Munsell N 9.25/		
Dimensions (H x W x D)	Net	in	13-6/16 x 45-4/16 x 9		
		mm	340 x 1,150 x 280		
	Gross	in	17-11/16 x 50 x 15-15/16		
		mm	450 x 1,270 x 405		
Weight	Net	lb (kg)	40 (18)		
	Gross		53 (24)		
Connection pipe	Size	Liquid	Ø3/8 (Ø9.52)		
		Gas	Ø5/8 (Ø15.88)		
	Method		Flare		
Drain hose	Material		PVC		
	Size		in (mm)	Ø9/16 (Ø13.8) (I.D.), Ø10/16 to Ø11/16 (Ø15.8 to Ø16.7) (O.D.)	
Operation range	Cooling	°F (°C)	64 to 90 (18 to 32)		
		%RH	80 or less		
Heating	°F (°C)	88 (30) or less			

Type	Wall mounted
	Inverter heat pump
Model name	UIWH30AVFJ
Remote controller type	Wireless (Wired [option])
<p>NOTES:</p> <ul style="list-style-type: none"> • Specifications are based on the following conditions: <ul style="list-style-type: none"> – Cooling: Indoor temperature of 80 °FDB (26.67 °CDB) /67 °FWB (19.44 °CWB), and outdoor temperature of 95 °FDB (35 °CDB) / 75 °FWB (23.9 °CWB). – Heating: Indoor temperature of 70 °FDB (21.11 °CDB) /59 °FWB (15 °CWB), and outdoor temperature of 47 °FDB (8.33 °CDB) /43 °FWB (6.11 °CWB). – Pipe length: 24 ft 6 in (7.5 m), Height difference: 0 ft (0 m). (Between outdoor unit and indoor unit.) • Protective function might work when using it outside the operation range. • *1: Maximum current is maximum value when operated within the operation range. • *2: Sound pressure level: <ul style="list-style-type: none"> – Measured values in manufacturer's anechoic chamber. – Because of the surrounding sound environment, the sound levels measured in actual installation conditions might be higher than the specified values here. 	

4. Dimensions

4-1. Model: UIWH30AVFJ

Unit: in (mm)

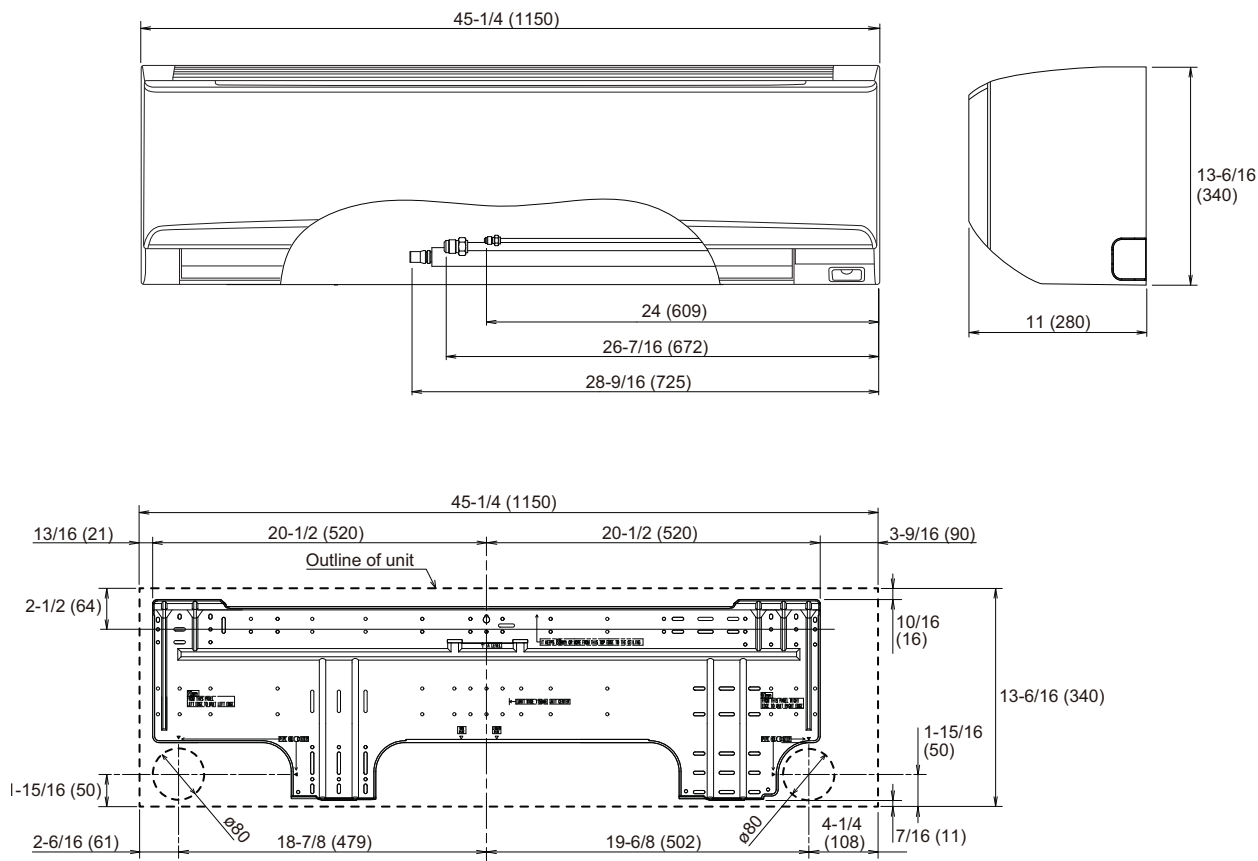

■ Installation space requirement

Provide sufficient installation space for product safety.

Unit: in (mm)

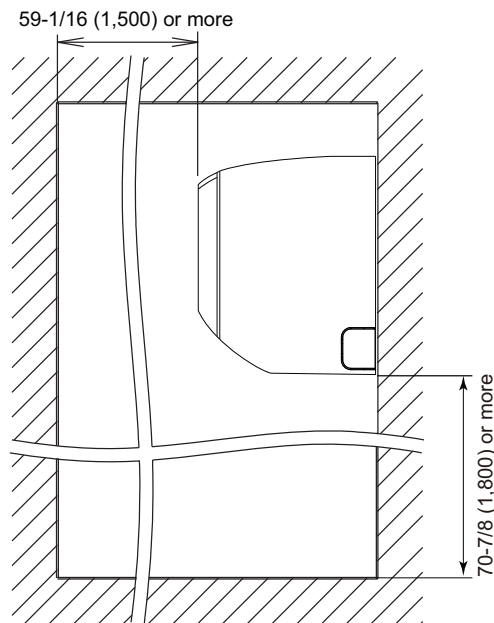
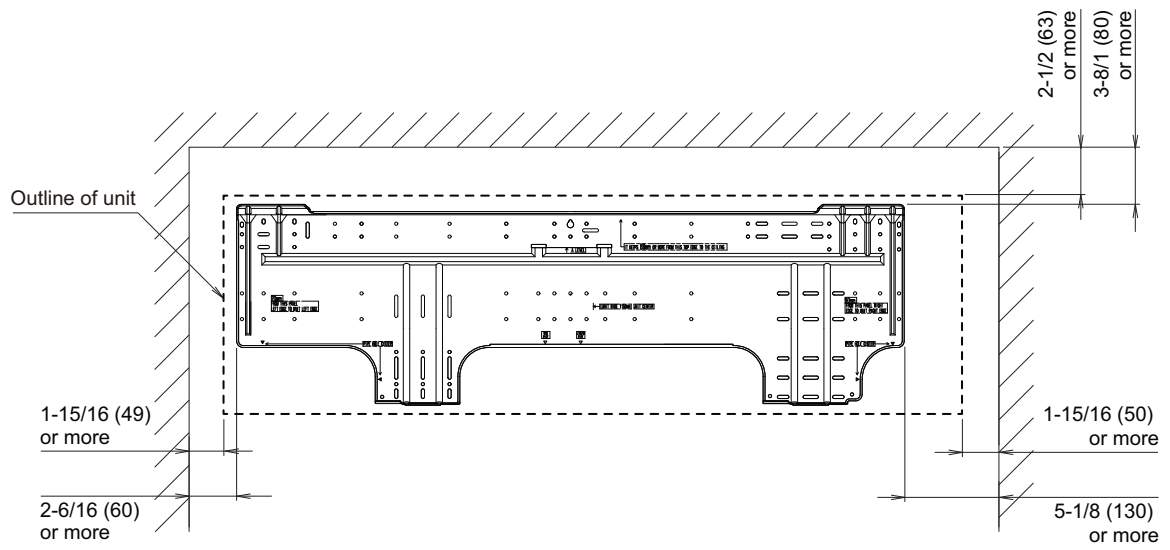

5. Wiring diagrams

5-1. Model: UIWH30AVFJ

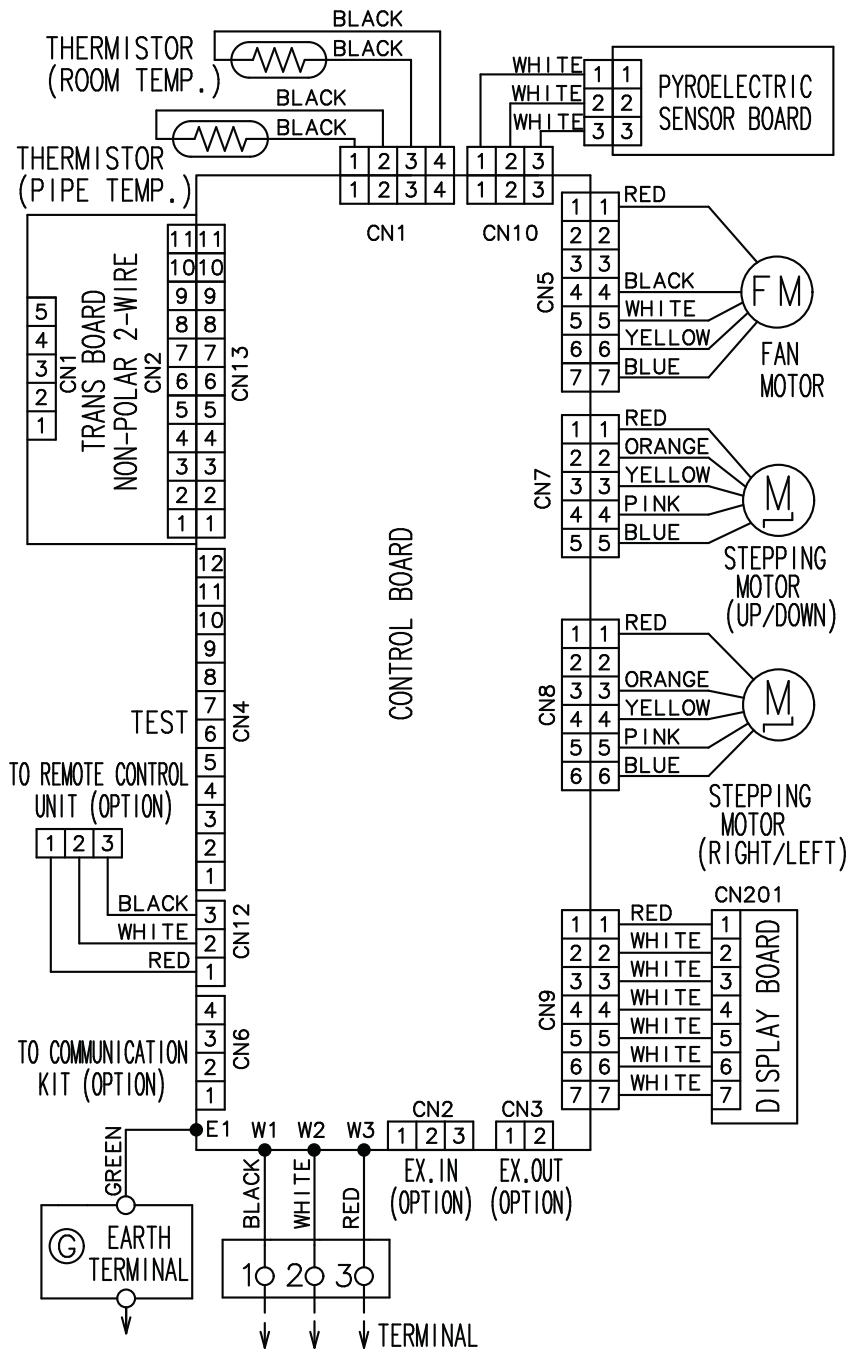

6. Capacity table

Capacity tables show each of following values calculated based on the outdoor temperature and the indoor temperature, under given Airflow Rate (AFR):

For cooling capacity: Total Capacity (TC), Sensible Heat Capacity (SHC), and Input Power (IP)

For heating capacity: Total Capacity (TC) and Input Power (IP)

6-1. Cooling capacity

■ Model: UIWH30AVFJ

AFR	CFM	812
-----	-----	-----

		Indoor temperature																		
		64			70			75			80			85			90			
		54			60			63			67			71			73			
Outdoor temperature	°FDB	TC	SHC	IP	TC	SHC	IP	TC	SHC	IP	TC	SHC	IP	TC	SHC	IP	TC	SHC	IP	
	°FWB	kBTu			kW			kBTu			kW			kBTu			kW			
-4	23.51	17.71	0.94	26.19	17.81	0.96	27.09	19.37	0.96	29.77	20.98	0.98	31.55	20.90	0.99	33.34	22.26	1.00		
5	22.97	17.52	1.17	25.59	17.62	1.18	26.46	19.16	1.19	29.08	20.75	1.21	30.82	20.67	1.22	32.56	22.02	1.23		
14	20.49	16.32	1.05	22.83	16.42	1.06	23.61	17.85	1.07	25.94	19.33	1.08	27.50	19.26	1.09	29.06	20.51	1.11		
23	24.67	18.36	0.90	27.48	18.47	0.91	28.41	20.08	0.92	31.22	21.75	0.93	33.10	21.67	0.94	34.97	23.08	0.95		
32	24.59	18.36	0.90	27.39	18.46	0.91	28.32	20.07	0.92	31.13	21.75	0.93	32.99	21.66	0.94	34.86	23.08	0.95		
41	22.97	17.51	1.10	25.59	17.61	1.12	26.46	19.14	1.12	29.07	20.74	1.14	30.82	20.66	1.15	32.56	22.01	1.16		
50	23.73	17.96	1.12	26.43	18.07	1.14	27.33	19.64	1.14	30.03	21.28	1.16	31.84	21.20	1.17	33.64	22.58	1.18		
59	22.53	17.39	1.32	25.10	17.49	1.35	25.95	19.02	1.35	28.52	20.60	1.37	30.23	20.52	1.39	31.94	21.86	1.40		
67	24.46	19.51	1.67	27.25	19.62	1.69	28.18	21.34	1.70	30.96	23.12	1.73	32.82	23.02	1.75	34.68	24.53	1.76		
77	25.98	18.95	1.94	28.94	19.06	1.97	29.93	20.72	1.98	32.89	22.45	2.01	34.86	22.36	2.03	36.84	23.82	2.05		
87	24.70	18.39	2.21	27.51	18.49	2.25	28.45	20.11	2.26	31.27	21.78	2.29	33.14	21.70	2.31	35.02	23.11	2.34		
95	24.18	18.21	2.34	26.93	18.31	2.37	27.85	19.91	2.39	30.60	21.57	2.42	32.44	21.49	2.45	34.28	22.89	2.47		
104	22.56	17.48	2.66	25.13	17.58	2.70	25.99	19.11	2.71	28.56	20.71	2.75	30.27	20.62	2.78	31.98	21.97	2.81		
115	14.19	13.87	1.99	15.81	13.95	2.02	16.35	15.17	2.03	17.96	16.43	2.06	19.04	16.37	2.08	20.12	17.43	2.10		

AFR	m ³ /h	1,380
-----	-------------------	-------

		Indoor temperature																		
		17.8			21.1			23.9			26.7			29.4			32.2			
		12.2			15.6			17.2			19.4			21.7			22.8			
Outdoor temperature	°CDB	TC	SHC	IP	TC	SHC	IP	TC	SHC	IP	TC	SHC	IP	TC	SHC	IP	TC	SHC	IP	
	°CWB	kW			kW			kW			kW			kW						
-20.0	6.89	5.19	0.94	7.68	5.22	0.96	7.94	5.68	0.96	8.72	6.15	0.98	9.25	6.13	0.99	9.77	6.52	1.00		
-15.0	6.73	5.13	1.17	7.50	5.16	1.18	7.75	5.61	1.19	8.52	6.08	1.21	9.03	6.06	1.22	9.54	6.45	1.23		
-10.0	6.01	4.78	1.05	6.69	4.81	1.06	6.92	5.23	1.07	7.60	5.67	1.08	8.06	5.64	1.09	8.52	6.01	1.11		
-5.0	7.23	5.38	0.90	8.05	5.41	0.91	8.33	5.88	0.92	9.15	6.38	0.93	9.70	6.35	0.94	10.25	6.76	0.95		
0.0	7.21	5.38	0.90	8.03	5.41	0.91	8.30	5.88	0.92	9.12	6.37	0.93	9.67	6.35	0.94	10.22	6.76	0.95		
5.0	6.73	5.13	1.10	7.50	5.16	1.12	7.75	5.61	1.12	8.52	6.08	1.14	9.03	6.05	1.15	9.54	6.45	1.16		
10.0	6.95	5.26	1.12	7.75	5.30	1.14	8.01	5.76	1.14	8.80	6.24	1.16	9.33	6.21	1.17	9.86	6.62	1.18		
15.0	6.60	5.10	1.32	7.36	5.13	1.35	7.61	5.57	1.35	8.36	6.04	1.37	8.86	6.01	1.39	9.36	6.41	1.40		
19.4	7.17	5.72	1.67	7.99	5.75	1.69	8.26	6.25	1.70	9.07	6.77	1.73	9.62	6.75	1.75	10.16	7.19	1.76		
25.0	7.62	5.55	1.94	8.48	5.59	1.97	8.77	6.07	1.98	9.64	6.58	2.01	10.22	6.55	2.03	10.80	6.98	2.05		
30.6	7.24	5.39	2.21	8.06	5.42	2.25	8.34	5.89	2.26	9.16	6.38	2.29	9.71	6.36	2.31	10.26	6.77	2.34		
35.0	7.09	5.34	2.34	7.89	5.37	2.37	8.16	5.84	2.39	8.97	6.32	2.42	9.51	6.30	2.45	10.05	6.71	2.47		
40.0	6.61	5.12	2.66	7.37	5.15	2.70	7.62	5.60	2.71	8.37	6.07	2.75	8.87	6.04	2.78	9.37	6.44	2.81		
46.1	4.16	4.06	1.99	4.63	4.09	2.02	4.79	4.45	2.03	5.26	4.82	2.06	5.58	4.80	2.08	5.90	5.11	2.10		

6-2. Heating capacity

■ Model: UIWH30AVFJ

AFR	CFM	812
-----	-----	-----

		Indoor temperature											
		°FDB		60		65		70		72		75	
		°FDB	°FWB	TC kBTu/h	IP kW	TC kBTu/h	IP kW	TC kBTu/h	IP kW	TC kBTu/h	IP kW	TC kBTu/h	IP kW
Outdoor temperature	-15	-17	24.02	3.80	23.45	3.87	22.88	3.95	22.30	4.02	21.73	4.10	
	-5	-7	28.62	4.04	27.94	4.12	27.26	4.20	26.57	4.28	25.89	4.36	
	5	3	33.64	4.37	32.83	4.46	32.03	4.55	31.23	4.64	30.43	4.72	
	14	12	36.64	4.33	35.77	4.41	34.89	4.50	34.02	4.59	33.15	4.67	
	23	19	37.59	4.37	36.69	4.46	35.80	4.54	34.90	4.63	34.01	4.72	
	32	28	39.07	4.27	38.14	4.36	37.21	4.44	36.28	4.53	35.35	4.61	
	41	37	38.98	3.60	38.05	3.67	37.12	3.75	36.19	3.82	35.26	3.90	
	47	43	39.09	3.30	38.16	3.36	37.23	3.43	36.29	3.50	35.36	3.57	
	50	47	39.35	3.20	38.41	3.27	37.47	3.34	36.54	3.40	35.60	3.45	
	59	50	40.13	2.93	39.17	2.99	38.21	3.05	37.26	3.11	36.30	3.16	

AFR	m ³ /h	1,380
-----	-------------------	-------

		Indoor temperature											
		°CDB		15.6		18.3		21.1		22.2		23.9	
		°CDB	°CWB	TC kW	IP kW	TC kW	IP kW	TC kW	IP kW	TC kW	IP kW	TC kW	IP kW
Outdoor temperature	-26.1	-27.2	7.04	3.80	6.87	3.87	6.70	3.95	6.54	4.02	6.37	4.10	
	-20.6	-21.7	8.39	4.04	8.19	4.12	7.99	4.20	7.79	4.28	7.59	4.36	
	-15.0	-16.1	9.86	4.37	9.62	4.46	9.39	4.55	9.15	4.64	8.92	4.72	
	-10.0	-11.1	10.74	4.33	10.48	4.41	10.23	4.50	9.97	4.59	9.72	4.67	
	-5.0	-7.2	11.02	4.37	10.75	4.46	10.49	4.54	10.23	4.63	9.97	4.72	
	0.0	-2.2	11.45	4.27	11.18	4.36	10.91	4.44	10.63	4.53	10.36	4.61	
	5.0	2.8	11.42	3.60	11.15	3.67	10.88	3.75	10.61	3.82	10.34	3.90	
	8.3	6.1	11.46	3.30	11.18	3.36	10.91	3.43	10.64	3.50	10.36	3.57	
	10.0	8.3	11.53	3.20	11.26	3.27	10.98	3.34	10.71	3.40	10.43	3.45	
	15.0	10.0	11.76	2.93	11.48	2.99	11.20	3.05	10.92	3.11	10.64	3.16	

7. Fan performance

7-1. Air velocity distributions

■ Model: UIWH30AVFJ

Measuring conditions	Fan speed	Operation mode
	HIGH	FAN

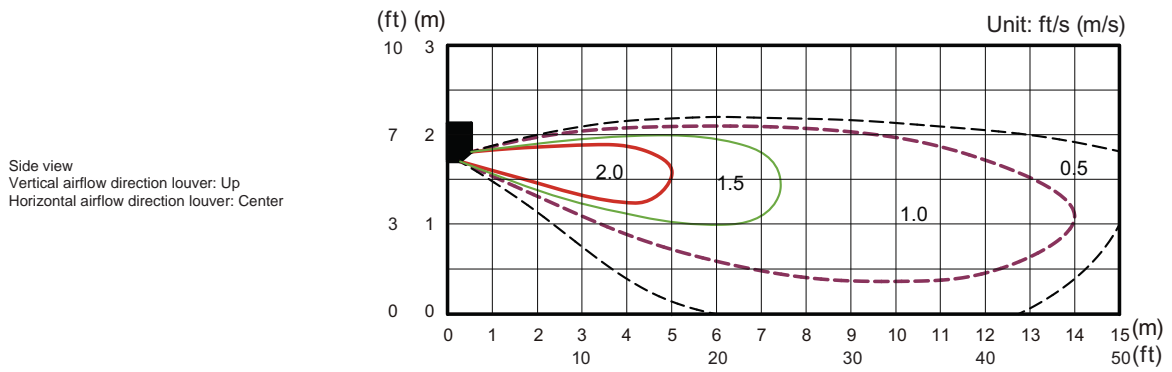
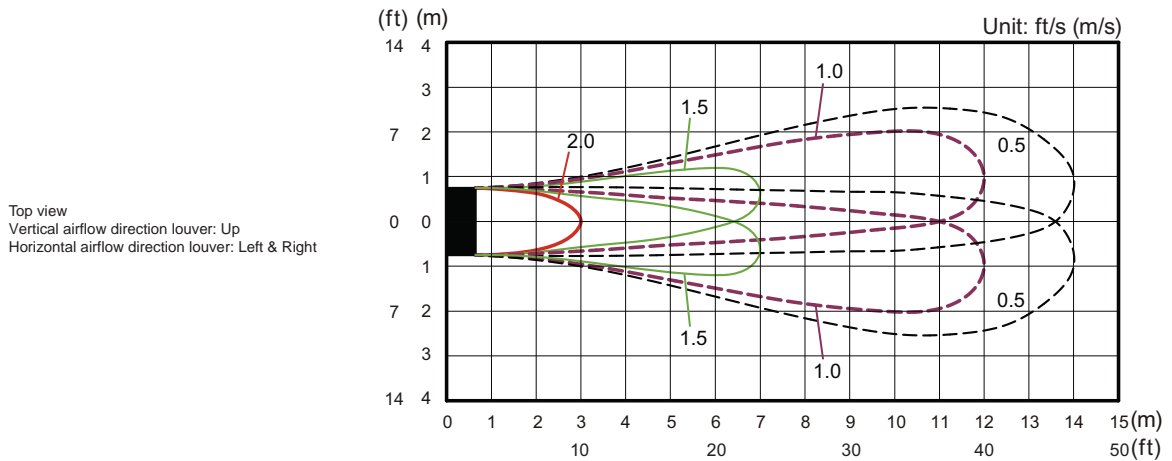
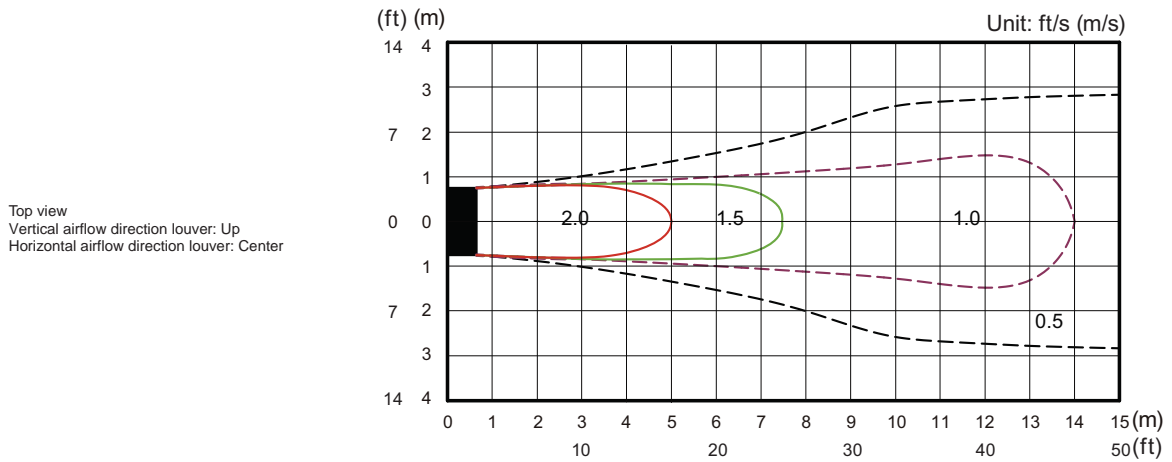

Side view
Vertical airflow direction louver: Down
Horizontal airflow direction louver: Center

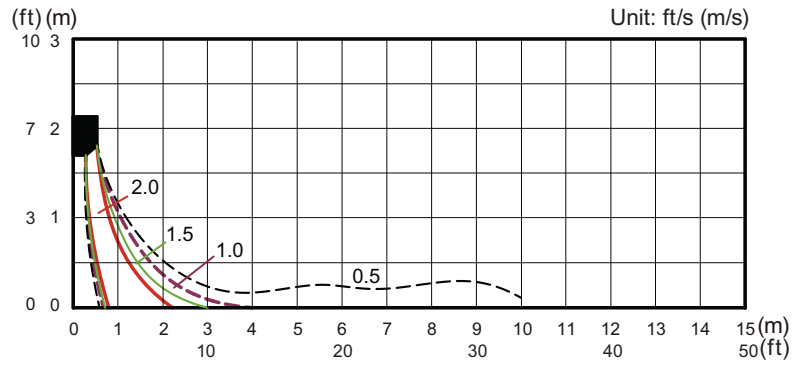

7-2. Airflow

■ Model: UIWH30AVFJ

● Cooling

Fan speed	Airflow	
HIGH	m ³ /h	1,380
	l/s	383
	CFM	812
MED	m ³ /h	1,130
	l/s	314
	CFM	665
LOW	m ³ /h	910
	l/s	253
	CFM	536
QUIET	m ³ /h	710
	l/s	197
	CFM	418

● Heating

Fan speed	Airflow	
HIGH	m ³ /h	1,380
	l/s	383
	CFM	812
MED	m ³ /h	1,130
	l/s	314
	CFM	665
LOW	m ³ /h	910
	l/s	253
	CFM	536
QUIET	m ³ /h	710
	l/s	197
	CFM	418

8. Operation noise (sound pressure)

8-1. Noise level curve

■ Model: ASU30RLE

● Cooling

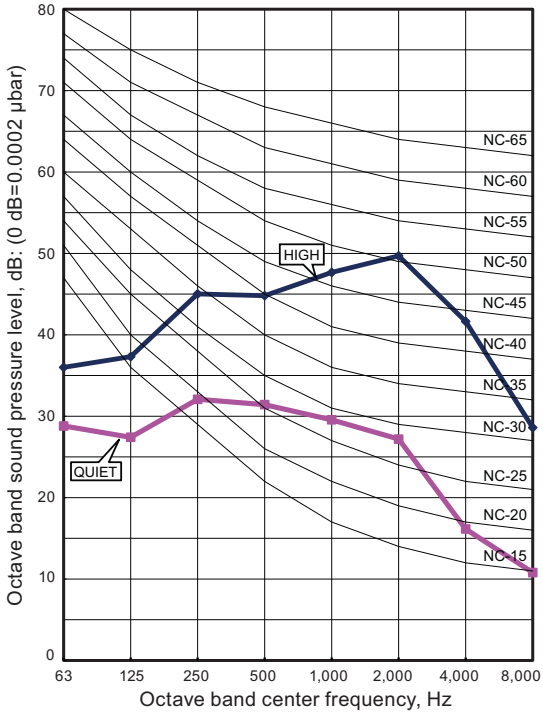

● Heating

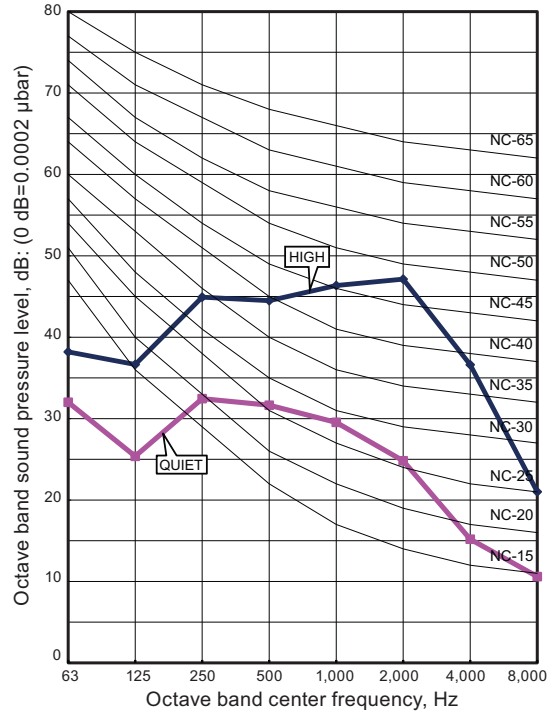

8-2. Sound level check point

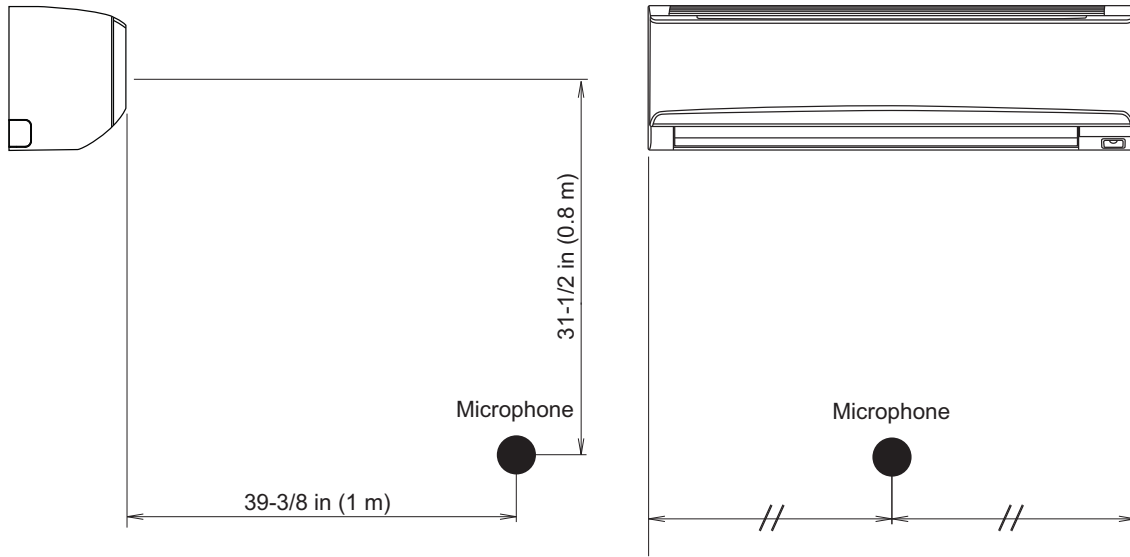

9. Safety devices

Type of protection	Protection form		Model
			UIWH30AVFJ
Circuit protection	Current fuse (PCB*)		250 V, 3.15 A
Fan motor protection	Thermistor protection	Activate	More than 185°F (85°C) Fan motor speed down
		Reset	Less than 185°F (85°C) Fan motor speed recover
	Power IC thermal shutdown protection	Activate	302±27°F (150±15°C) Fan motor stop
		Reset	Less than 275°F (135°C) Fan motor restart

*PCB: Printed Circuit Board

10. External input and output

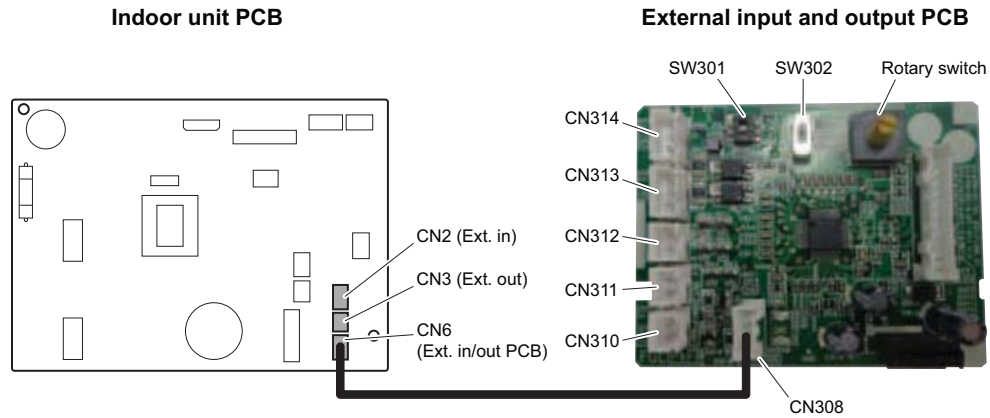

PCB	External input	External output	Connector	Input select	Input signal
Indoor unit	Operation/Stop	-	CN2	Dry contact	Edge
	Forced stop				
	-	Operation status	CN3	-	-
		Error status			
Indoor unit fan operation status					
Set point attainment status					
External input and output	Operation/Stop	-	CN313/ CN314	Dry contact/ Apply voltage	Edge/Pulse
	Forced stop				
	Forced thermostat off		CN313	Edge	
	-	Operation status	CN310	-	-
Error status		CN311			
Indoor unit fan operation status		CN312			

10-1. External input

With using external input function, some functions on this product can be controlled from an external device.

- "Operation/Stop" mode or "Forced stop" mode can be selected with function setting of indoor unit.
- A twisted pair cable (22AWG) should be used. Maximum length of cable is 492 ft (150 m).
- The wire connection should be separate from the power cable line.

■ Indoor unit

Indoor unit functions such as Operation/Stop can be done by using indoor unit connectors.

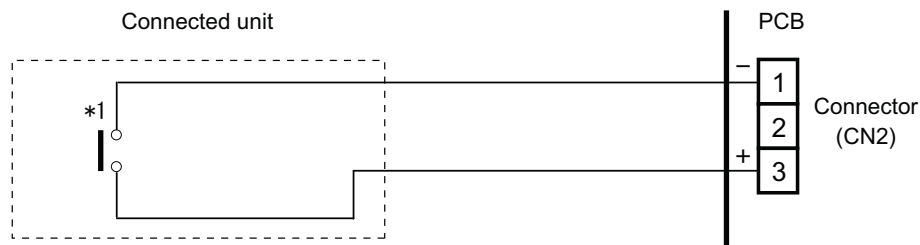

*1: The switch can be used on the following condition: DC 12 V to 24 V, 1 mA to 15 mA.

■ External input and output PCB

The indoor unit Operation/Stop can be set by using the input connector on the PCB.

● Input select

Use either one of these types of connectors according to the application. (Both types of connectors cannot be used simultaneously.)

- Dry contact

In case of internal power supply, set the slide switch of SW301 to "NON VOL" side.

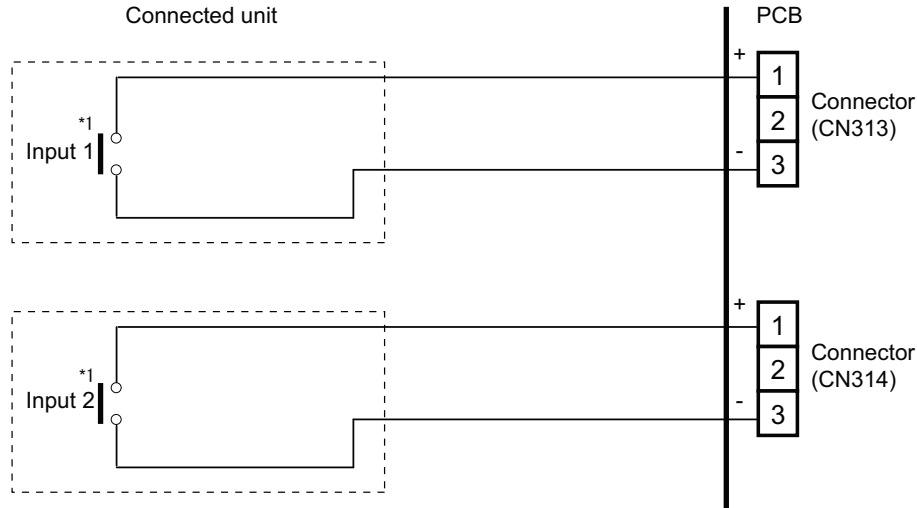

*1: The switches can be used on the following condition: DC 12 V to 24 V, 1 mA to 15 mA.

- Apply voltage

In case of external power supply, set the slide switch of SW301 to "VOL" side.

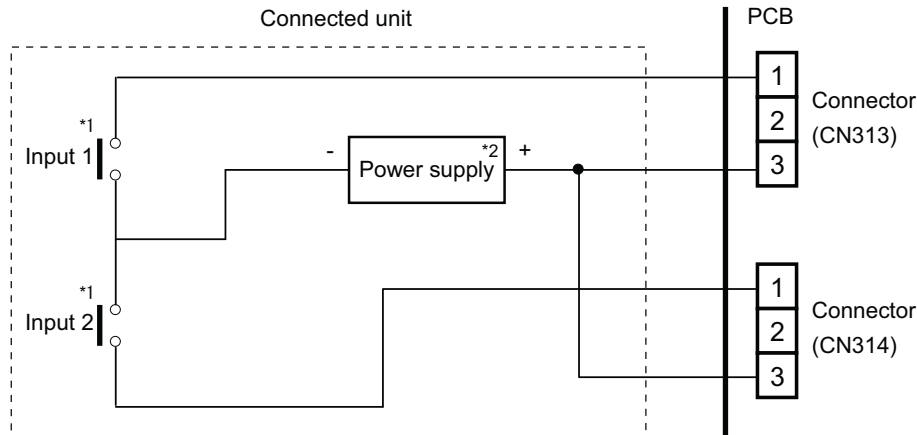

*1: The switches can be used on the following condition: DC 12 V to 24 V, 1 mA to 15 mA.

*2: Make the power supply DC 12 to 24 V, 10 mA or more.

10-2. External output

Use an external output cable with appropriate external dimension, depending on the number of cables to be installed.

■ Indoor unit

- A twisted pair cable (22AWG) should be used. Maximum length of cable is 82 ft (25 m).
- Output voltage: High DC 12 V \pm 2 V, Low 0 V.
- Permissible current: 50 mA
- For details, refer to Chapter 10-3. "[Combination of external input and output](#)" on page 29.

● When indicator or other components are connected directly

Example: Function setting 60 is set to "00"

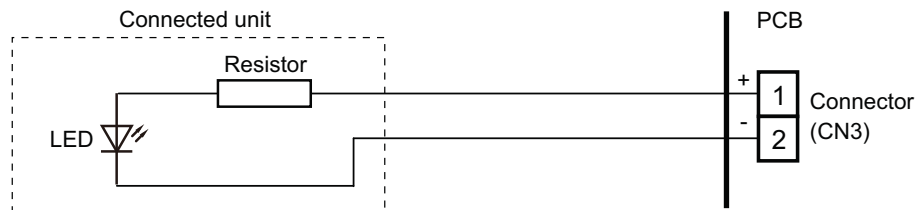

● When connecting with a device equipped with a power supply

Example: Function setting 60 is set to "00"

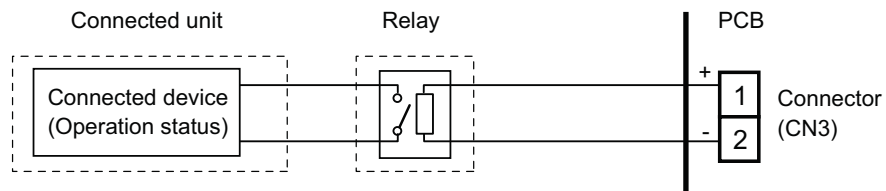

External input and output PCB

- A twisted pair cable (22AWG) should be used. Maximum length of cable is 82 ft (25 m).
- Output voltage: High DC 12 V \pm 2 V, Low 0 V.
- Permissible current: 50 mA
- For details, refer to Chapter 10. "Combination of external input and output" on page 29.

When indicator or other components are connected directly

Example: Function setting 60 is set to "00".

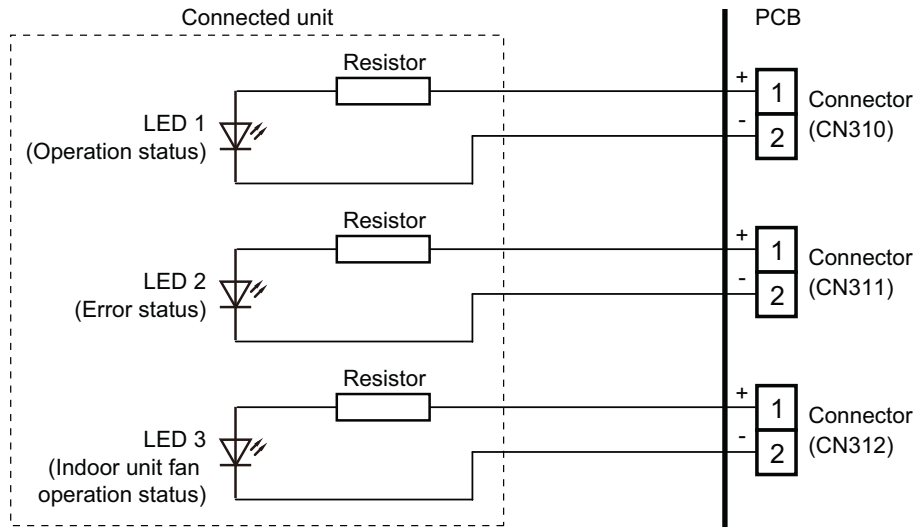

When connecting with a device equipped with a power supply

Example: Function setting 60 is set to "00".

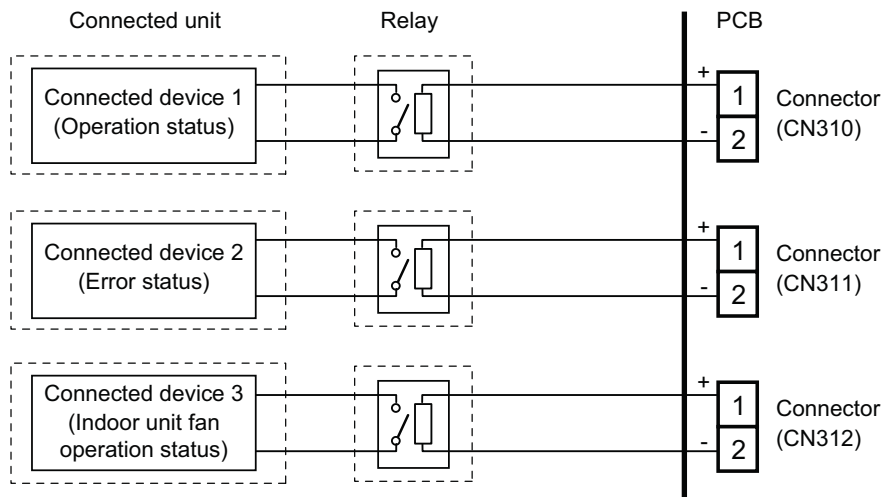

10-3. Combination of external input and output

By combining the function setting of the indoor unit and rotary switch setting of the External input and output PCB, you can select various combinations of functions.

Combination examples of external input and output are as follows:

Mode	Function setting	Rotary SW	External input		
			Indoor unit	External input and output PCB	
			CN2	1 CN313	2 CN314
0-1	60—00	1	Operation/Stop (Function setting 46-00) or Emergency stop (Function setting 46-01) or Forced stop (Function setting 46-02)	Operation/Stop	Not available
				Operation	Stop
0-2	60-00	2		Forced thermostat Off	Not available
1	60-01	3		Mechanical cooling Off	
2	60-02	4		Forced thermostat Off	
3	60-03	5		Mechanical cooling On	
4	60-04	6		Mechanical cooling On	
5	60-05	7		Forced thermostat Off	
6	60-06	8		Forced thermostat Off	
7	60-07	9		Mechanical cooling Off	
8	60-08	A		Forced thermostat Off	
9	60-09	B		Forced thermostat Off	
10	60-10	C	Forced thermostat Off		
11	60-11	D	Forced thermostat Off		
12	60-12	D	Forced thermostat Off		

Mode	Function setting	Rotary SW	External output			
			Indoor unit	External input and output PCB		
			CN3	1 CN310	2 CN311	3 CN312
0-1	60-00	1	Operation/Stop	Operation/Stop	Error status	Indoor unit fan operation status
0-2	60-00	2	Operation/Stop	Error status	Indoor unit fan operation status	External heater output
1	60-01	3	Cooling thermostat On	Error status	Indoor unit fan operation status	External heater output
2	60-02	4	Cooling thermostat On	Error status	Remote controller output	External heater output
3	60-03	5	Cooling thermostat On	Cooling high/low output	Remote controller output	External heater output
4	60-04	6	Cooling thermostat On	Error status	Remote controller output	Cooling high/low output
5	60-05	7	Heating thermostat On	Error status	Indoor unit fan operation status	External heater output
6	60-06	8	Operation/Stop	Error status	Indoor unit fan operation status	Heating thermostat On
7	60-07	9	Cooling thermostat On	Error status	Heating thermostat On	External heater output

Mode	Function setting	Rotary SW	External output			
			Indoor unit	External input and output PCB		
			CN3	1 CN310	2 CN311	3 CN312
8	60-08	A	Cooling thermostat On	Heating thermostat On	Remote controller output	External heater output
9	60-09	B	Error status	Operation/Stop	Indoor unit fan operation status	External heater output
10	60-10	C	Indoor unit fan operation status	Operation/Stop	Error status	External heater output
11	60-11	D	External heater output	Operation/Stop	Indoor unit fan operation status	Error status
12	60-12	D	Set point attainment status	Operation/Stop	Indoor unit fan operation status	Error status

NOTE: Input of Operation/Stop depends on the setting of function setting 46.

00: Operation/Stop mode 1 (R.C. enabled)

01: (Setting prohibited)

02: Forced stop

03: Operation/Stop mode 2 (R.C. disabled)

■ Input signal type

- **Indoor unit**

Input signal type is only "Edge".



- **External input and output PCB**

The input signal type can be selected.

Signal type (edge or pulse) can be switched by the DIP switch SW302 on the External input and output PCB.

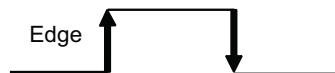

The width of pulse must be longer than 200 msec.



10-4. Details of function

■ Control input function

● When function setting is "Operation/Stop" mode 1

- In the case of "Edge" input

Mode	Function setting /	Rotary SW on External input and output PCB	External input		Input signal	Command
0-1	46-00	-	Input of indoor unit	CN2	Off → On	Operation
					On → Off	Stop
		60-00 / 1	External input and output PCB	CN313	Off → On	Operation
					On → Off	Stop

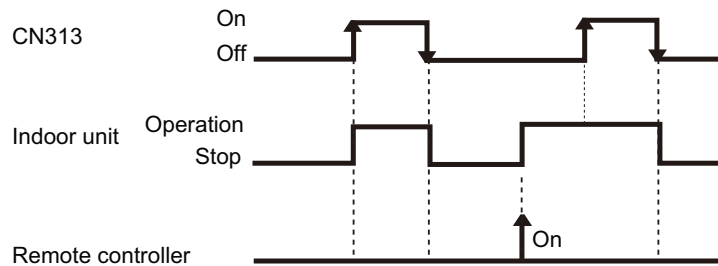

- In the case of "Pulse" input

Mode	Function setting /	Rotary SW on External input and output PCB	External input		Input signal	Command
0-1	46-00	60-00 / 1	External input and output PCB	CN313	Pulse	Operation
				CN314	Pulse	Stop

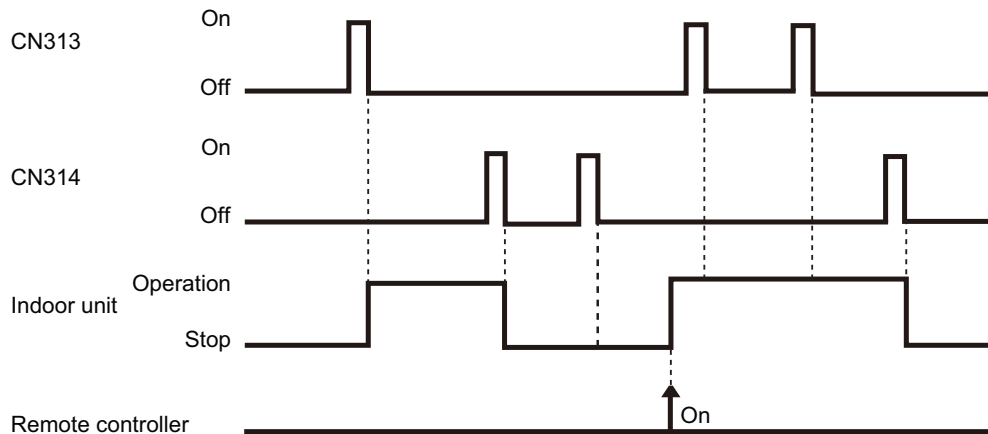

NOTES:

- The last command has priority.
- The indoor units within the same remote controller group operates in the same mode.
- This function is invalid when function setting 96 is set to "02" (Secondary unit).

● When function setting is "Forced stop" mode

- In the case of "Edge" input

Mode	Function setting /	Rotary SW on External input and output PCB	External input		Input signal	Command
0-1	46-02	-	Input of indoor unit	CN2	Off → On	Forced stop
					On → Off	Normal
		60-00 / 1	External input and output PCB	CN313	Off → On	Forced stop
					On → Off	Normal

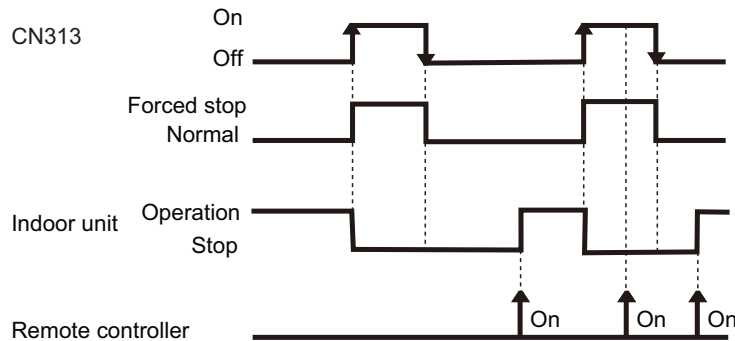

- In the case of "Pulse" input

Mode	Function setting /	Rotary SW on External input and output PCB	External input		Input signal	Command
0-1	46-02	60-00 / 1	External input and output PCB	CN313	Pulse	Forced stop
				CN314	Pulse	Normal

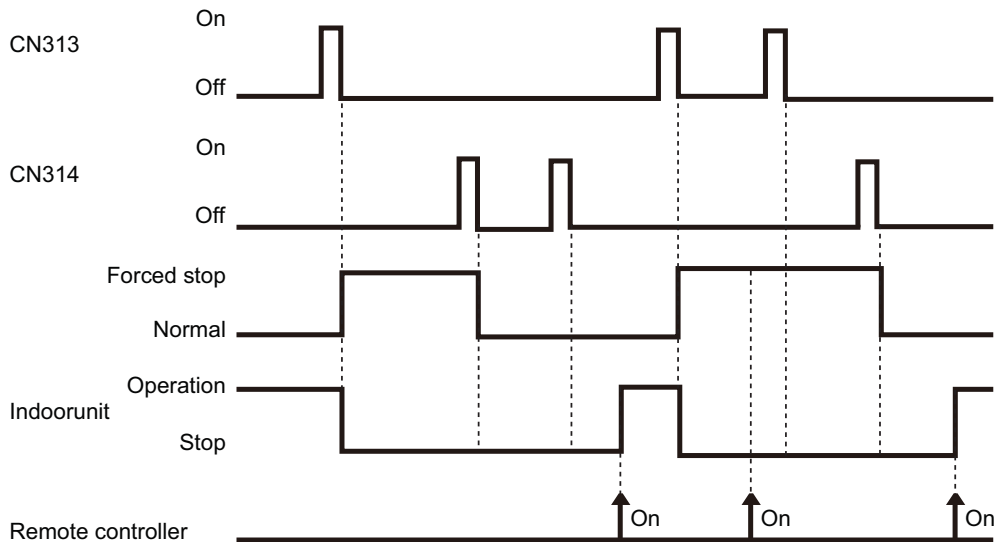

NOTES:

- When the forced stop is triggered, indoor unit stops and Operation/Stop operation by the remote controller is restricted.
- When forced stop function is used with forming a remote controller group, connect the same equipment to each indoor unit within the group.
- This function is invalid when function setting 96 is set to "02" (Secondary unit).

● When function setting is "Operation/Stop" mode 2

- In the case of "Edge" input

Mode	Function setting /	Rotary SW on External input and output PCB	External input		Input signal	Command
0-1	46-03	-	Input of indoor unit	CN2	Off → On	Operation
					On → Off	Stop (R.C. disabled)
		60-00 / 1	External input and output PCB	CN313	Off → On	Operation
					On → Off	Stop (R.C. disabled)

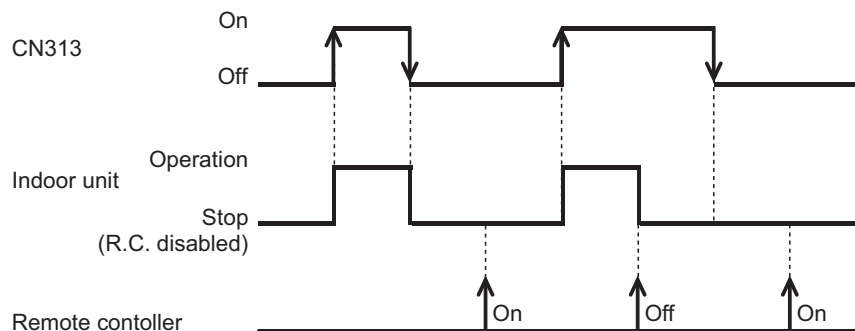

- In the case of "Pulse" input

Mode	Function setting /	Rotary SW on External input and output PCB	External input		Input signal	Command
0-1	46-03	60-00 / 1	External input and output PCB	CN313	Pulse	Operation
				CN314	Pulse	Stop (R.C. disabled)

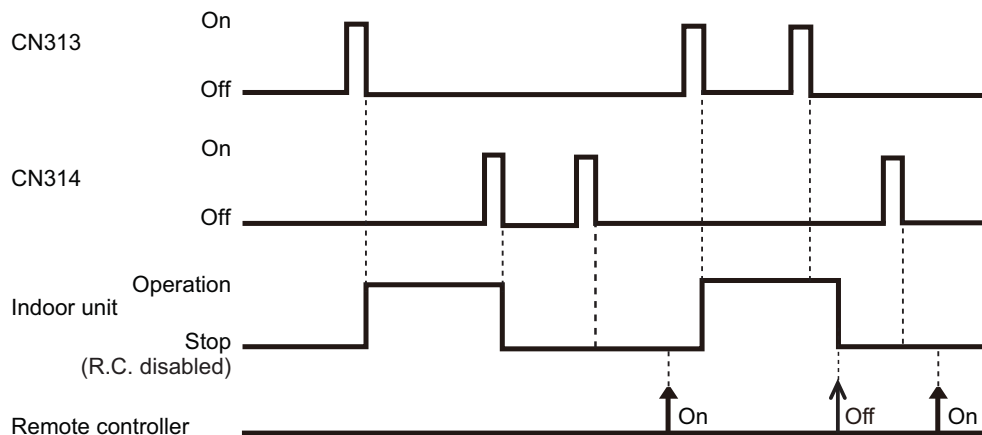

NOTES:

- When "Operation/Stop" mode 2 function is used with forming a remote controller group, connect the same equipment to each indoor unit within the group.
- This function is invalid when function setting 96 is set to "02" (Secondary unit).

● Forced thermostat off function

Mode	Function setting /	Rotary SW on External input and output PCB	External input		Input signal	Command
0-1 9 10		60-00 / 2 60-09 / B 60-10 / C	External input and output PCB	CN313	Off → On	Thermostat off
					On → Off	Normal operation

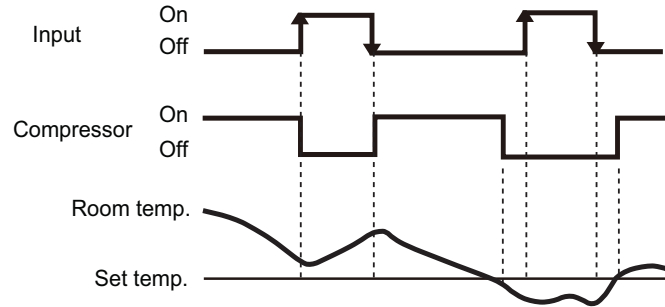

• Example of individual connection

Forced thermostat off is one of the function to save energy. For example, case of using ventilator at condition with outdoor temperature is lower than indoor temperature, indoor unit of air conditioner stop based upon receiving signal from external controller. (Cooling only)

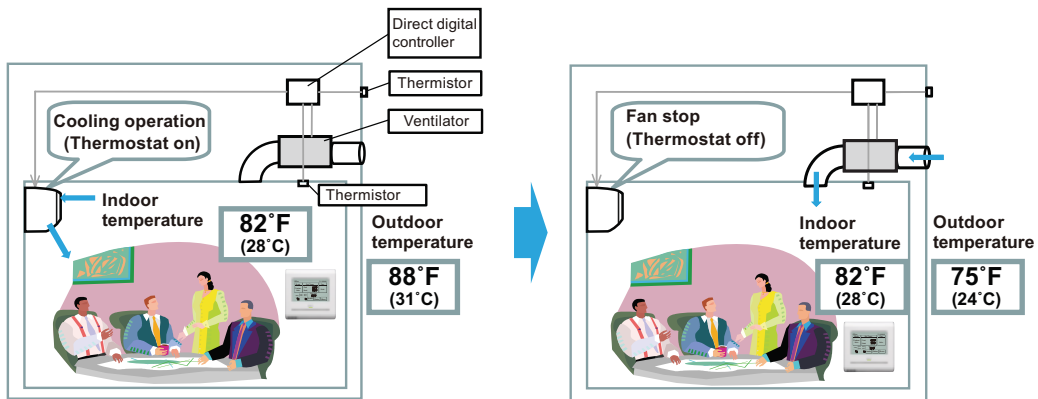

- System figure example

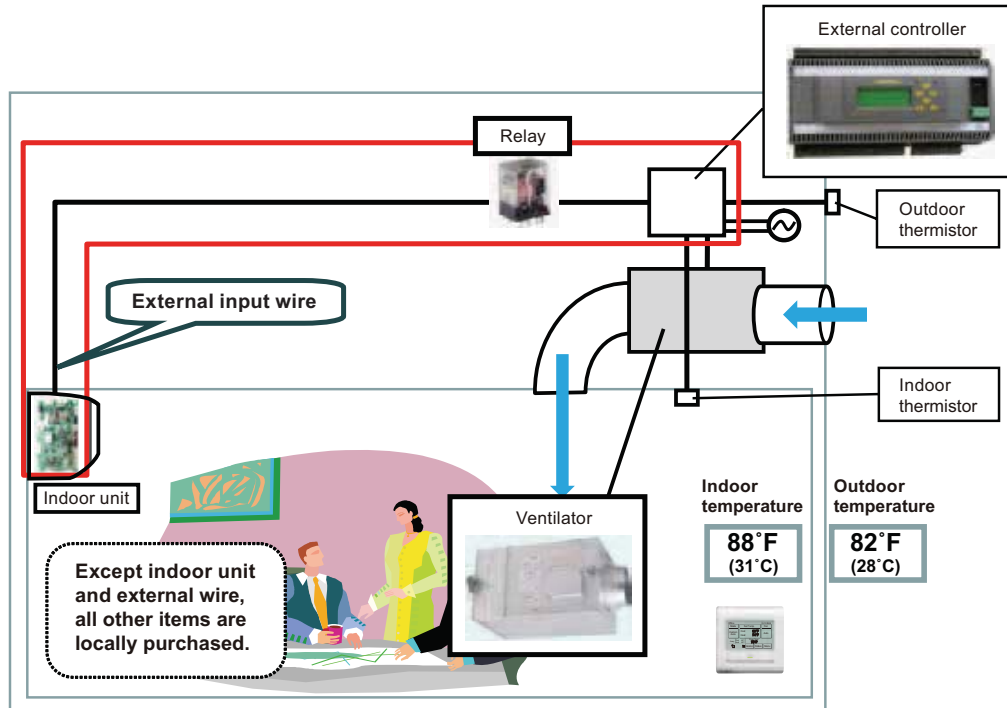

- Operation status

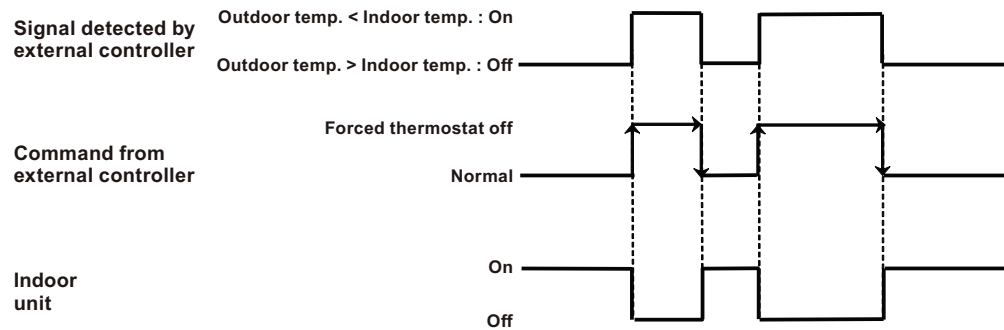

Normal means that indoor unit continues to operate until “Forced thermostat Off” signal received, at condition which are set by central and individual controller or detected by thermo sensors of indoor unit.

Indoor unit continues to operate until “Forced thermostat Off” signal received, at condition which are set by central and individual controller or detected by thermo sensors of indoor unit. Once “Forced thermostat Off” signal received, indoor unit stop operation.

■ Control output function

● Operation/Stop status

Mode	Function setting /	Rotary SW on External input and output PCB	External output		Output signal	Command
0-1 0-2		60-00 / 1, 2	Output of indoor unit	CN3	Low → High	Operation
					High → Low	Stop
0-1		60-00 / 1	External input and output PCB	CN310	Off → On	Operation
					On → Off	Stop

The output is low when the unit is stopped.

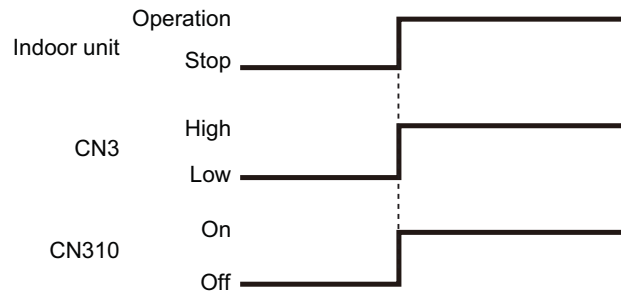

● Error status

Mode	Function setting /	Rotary SW on External input and output PCB	External output		Output signal	Command
9		60-09 / B	Output of indoor unit	CN3	Low → High	Error
					High → Low	Normal
0-1		60-00 / 1	External input and output PCB	CN311	Off → On	Error
					On → Off	Normal

The output is ON when an error is generated for the indoor unit.

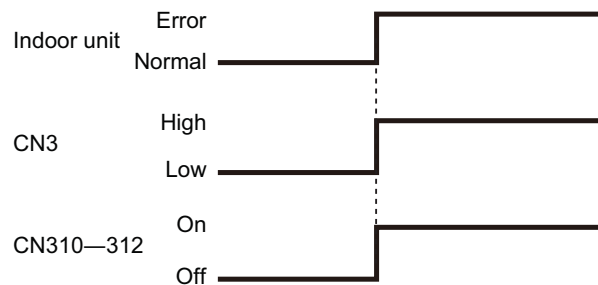

● Indoor unit fan operation status

Mode	Function setting /	Rotary SW on External input and output PCB	External output		Output signal	Command
10		60-10 / C	Output of indoor unit	CN3	Low → High	Fan run
					High → Low	Fan stop
0-1		60-00 / 1	External input and output PCB	CN312	Off → On	Fan run
					On → Off	Fan stop

Output signal	Condition
On Low → High	The indoor unit fan is operating.
Off High → Low	The fan is stopped or during cold air prevention. During thermostat off when in dry mode operation.

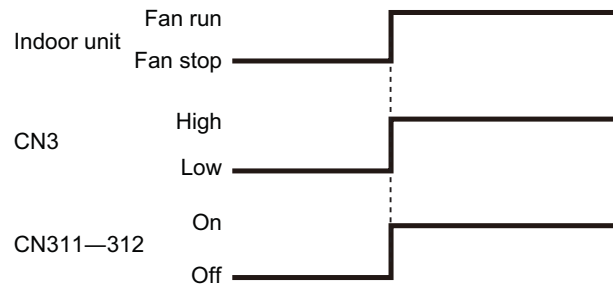

● Set point attainment status

NOTE: This function is valid only when function setting 96 is set to “01” (Primary unit) or “02” (Secondary unit).

When the room temperature does not reach the set point at a room due to the lower cooling performance caused by external factor such as the outdoor temperature change, signal is output to tell the attainment status of set point.

Mode	Function setting /	Rotary SW on External input and output PCB	External output		Output signal	Command
12		60-12 / D	Output of indoor unit	CN3	On → Off	Normal
					Off → On	Set point attainment

Output signal	Condition
Off	Reached the set point. ($T_r \leq T_{s\alpha} + 1^\circ\text{F}$ [0.5°C])
On	Unreached the set point. ($T_r > T_{s\alpha} + 5^\circ\text{F}$ [2.5°C]) However, even if the set point unreached, the signal will not be output for 7 minutes after power is turned on.

When performing the server room control, both of the primary unit and secondary unit output the set point attainment status if any of the unit is outputting alternative operation command.

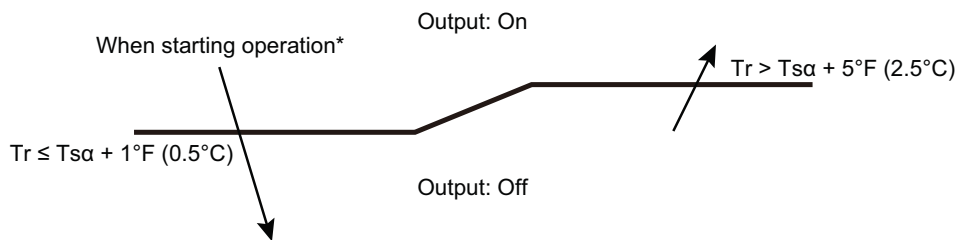

*: When starting operation or resetting, judges the zone to descending direction.

■ Fresh air conditioner (for external control module*) input function (mode 1 or 7)

* Module that reduces or stops the cooling operating ratio of the air conditioner by intaking fresh air such as Direct digital controller.

Mode	Function setting	External input	External output	Input signal*	Command
1 7	60-01	CNA03 or CNA04 (EXT. IN2)	CNB01 (Pin: 1-2) Cooling thermostat On	Off → On	Mechanical cooling Off
	60-07	Mechanical cooling Off		On → Off	Normal operation

* Edge input only.

- With using “Fresh air conditioner” input and “Cooling thermostat On” output, external control module controls the cooling operation by the air conditioner.
- When “Fresh air conditioner On” is input during cooling thermostat on, fresh air conditioning is performed with stopping the cooling operation by the air conditioner.

NOTE: During operations other than cooling such as heating or dry, “Fresh air conditioner On” input is disabled.

• Example of individual connection

Output: Cooling thermostat On

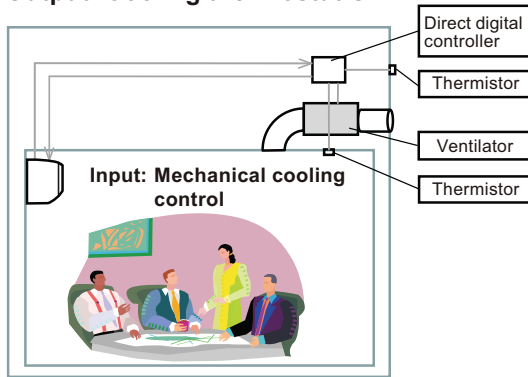

① Output: Off (Cooling thermostat Off)

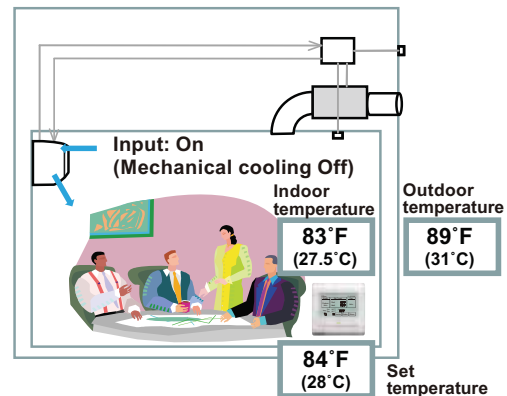

② Output: On (Cooling thermostat On)

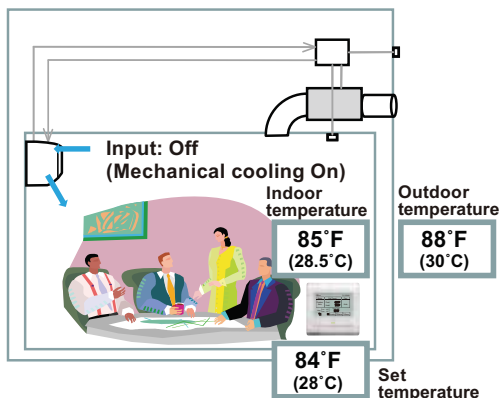

③ Output: On (Cooling thermostat On)

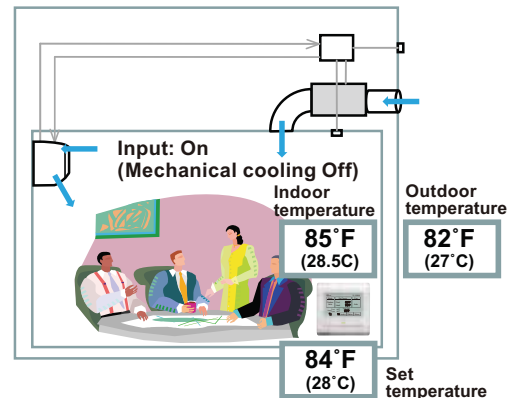

• Operation status

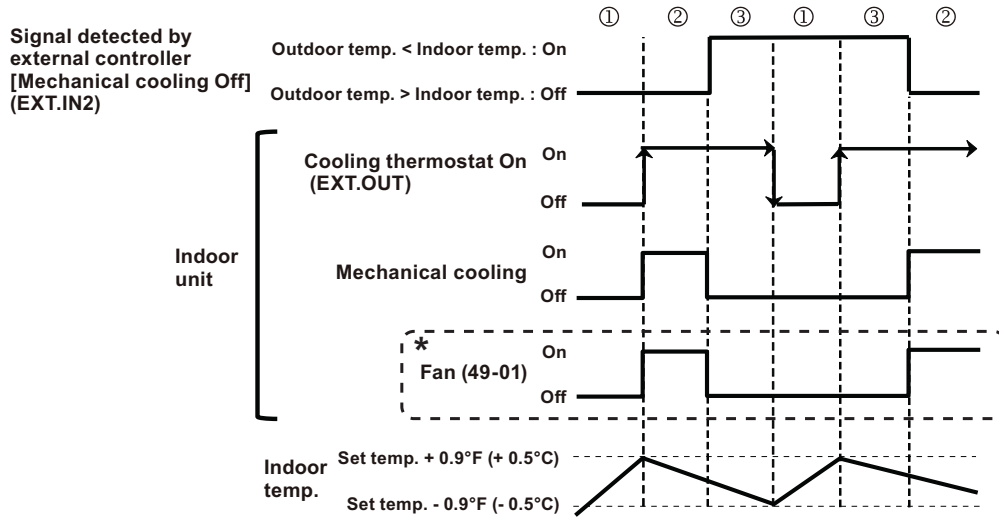

*: This status follows the configuration on function setting 49.

- 0: Setting airflow (When comp. on)
- 1: Intermittent S-Lo (On: 1 minute and off: 3 minutes)
- 2: Remote controller setting (Either of 0 or 1)

External heater output

Control	Primary heater	Auxiliary heater	Function setting	
			Indoor unit	Wired R. C.
			Control switching external heaters No. 61	Sensor activation
Auxiliary heater control 1	RAC heat pump	External device (Hot water electrical heater, etc.)	61-00	—
Auxiliary heater control 2	RAC heat pump	External device (Hot water electrical heater, etc.)	61-01	—
Heat pump prohibition control	External device (Hot water electrical heater, etc.)	None	61-02	On (Enabled)*
Heater selection control by outdoor temperature 1	RAC heat pump	External device (Hot water electrical heater, etc.)	61-03	On (Enabled)*
Heater selection control by outdoor temperature 2	External device (Hot water electrical heater, etc.)	RAC heat pump	61-04	On (Enabled)*

NOTES:

- After turning off the heater, 3 minutes of standby time is required by next power-on of the heater.
- For items marked “—” in the table, any of validate or invalidate of the setting are acceptable.
- *: setting change from the factory setting is required.
- *: Indoor unit fan setting will be on for safety reason without sensor activation of wired remote controller.

Installation configuration of individual connection

External heating device is installed individually. (No use of indoor unit fan)

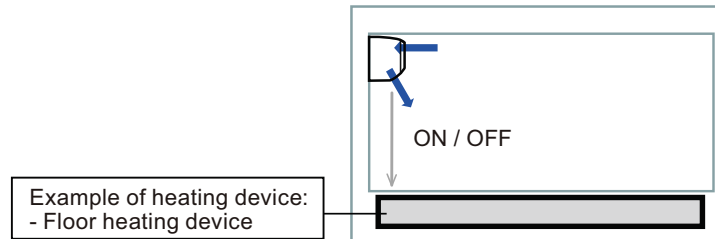

⚠ WARNING

- When auxiliary heater is installed, always set “indoor unit fan setting for external heater”.
- Design and install external heater appropriately with considering its protection.

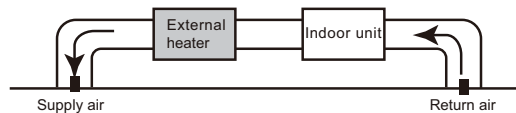

- Inappropriate designing and installation of external heater may cause a fire by emitted heat from the external heater.
-

● Auxiliary heater control 1

Operation	Condition
Heater on	Heater is on as shown in following diagram of heating temperature.
Heater off	<ul style="list-style-type: none"> • Heater is off as shown in following diagram of heating temperature. • Other than heating mode • Error occurred • Forced thermostat off • Fan stop protection

- Temperature of heater on (Thon): Adjustable by function setting no. 62 (Operating temperature switching of external heaters).
- All control temperatures will shift by adjusting "Thon".

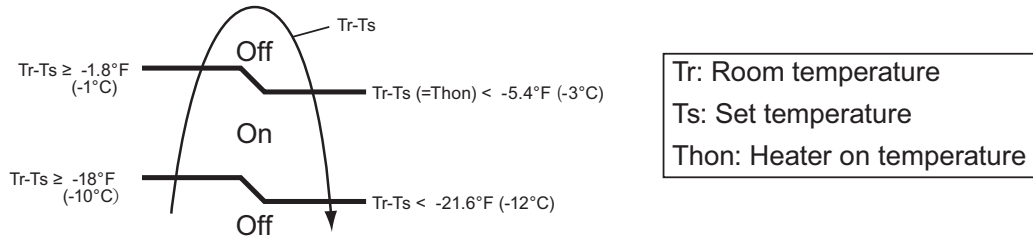

Example: When set temperature (Ts) is 72°F (22°C) (Factory setting),

- and room temperature (Tr) increases above 53.6°F (12°C), signal output is on.
- and room temperature (Tr) increases above 69.8°F (21°C), signal output is off.
- and room temperature (Tr) decreases below 66.2°F (19°C), signal output is on.
- and room temperature (Tr) decreases below 50°F (10°C), signal output is off.

● Auxiliary heater control 2

Operation	Condition
Heater on	Heater is on as shown in following diagram of heating temperature.
Heater off	<ul style="list-style-type: none"> • Heater is off as shown in following diagram of heating temperature. • Other than heating mode • Error occurred • Forced thermostat off • Fan stop protection

- Temperature of heater on (Thon): Adjustable by function setting no. 62 (Operating temperature switching of external heaters).
- All control temperatures will shift by adjusting "Thon".

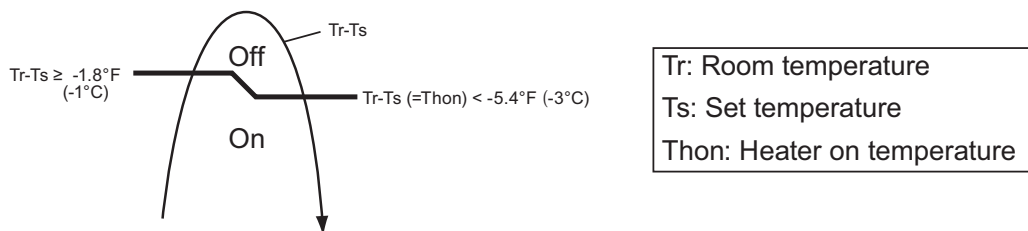

● Heat pump prohibition control

Operation	Condition
Heater on	Heater is on as shown in following diagram of heating temperature.
Heater off	<ul style="list-style-type: none"> • Heater is off as shown in following diagram of heating temperature. • Other than heating mode • Error occurred • Forced thermostat off

- Temperature of heater on (Thon): Adjustable by function setting no. 62 (Operating temperature switching of external heaters).
- All control temperatures will shift by adjusting "Thon".

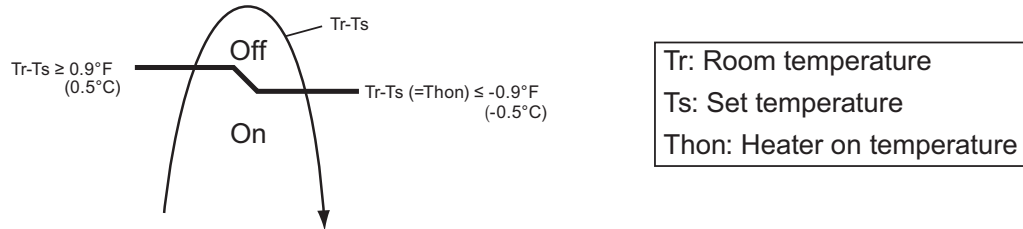

Operation status

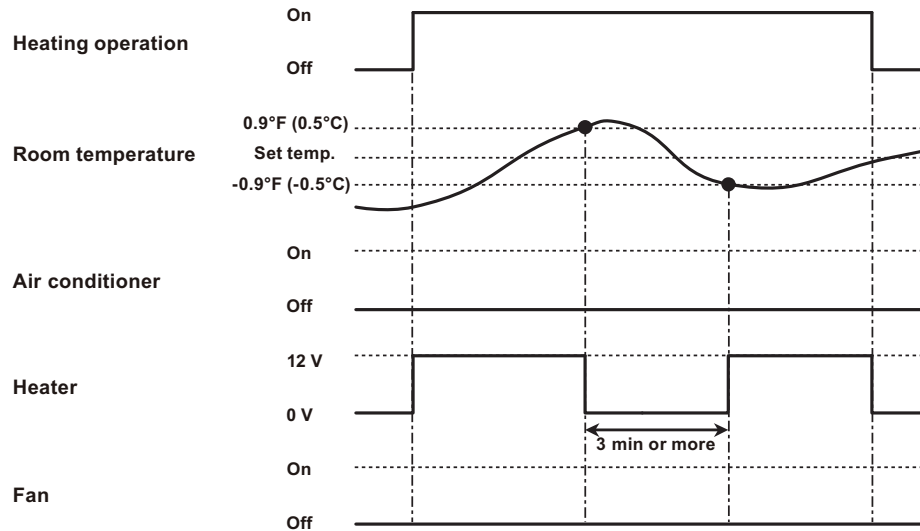

NOTE: In following operations, compressor will be on.

- Other than heating
- Test run

● Heater selection control by outdoor temperature 1

Operation	Condition
Heater on	Heater is on as shown in following diagram of heating temperature.
Heater off	<ul style="list-style-type: none"> • Heater is off as shown in following diagram of heating temperature. • Other than heating mode • Error occurred • Forced thermostat off • Heat pump only zone

- Temperature of heater on (Thon): Adjustable by function setting no. 62 (Operating temperature switching of external heaters).
- All control temperatures will shift by adjusting “Thon”.
- Outdoor temperature zone boundary A and B: Adjustable individually by function setting no. 36 and 37 for outdoor unit.

• External heater output

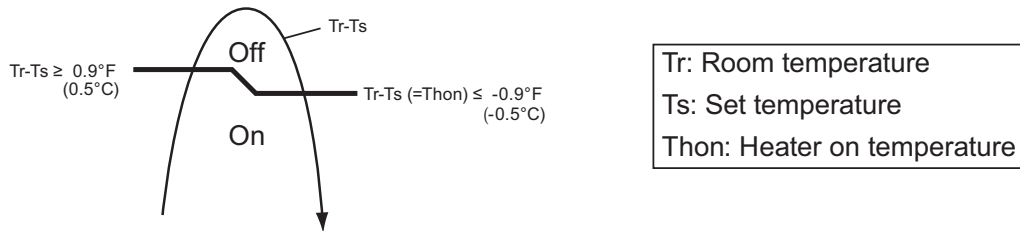

• Outdoor temperature zone

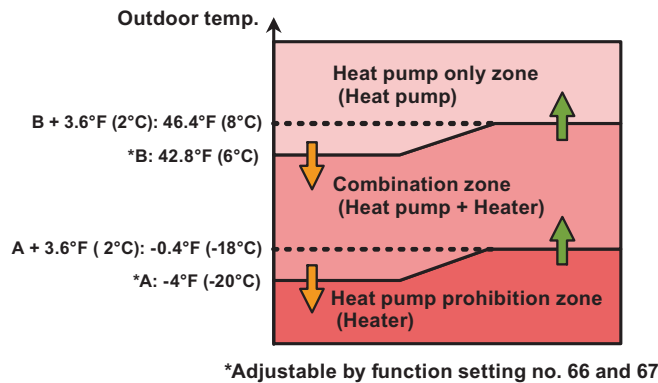

• Operation status

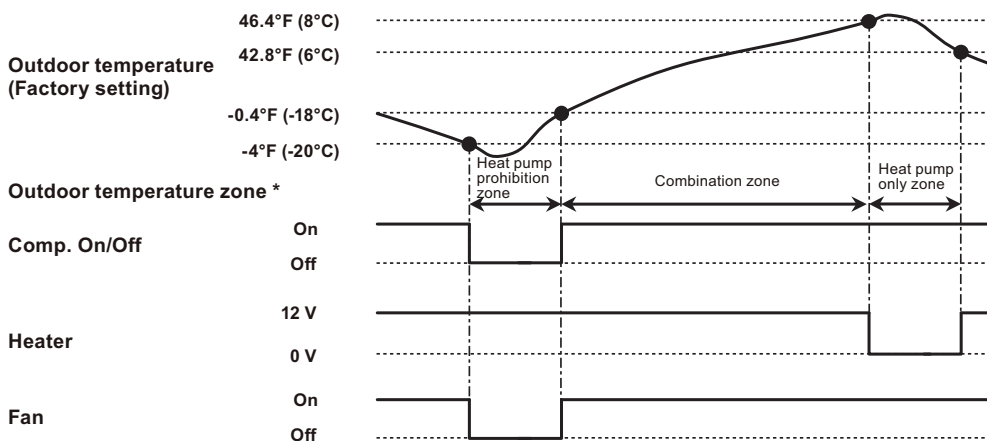

* The outdoor temperature zone transition from one to another will stay in that zone for minimum of 30 min.

NOTE: In following operations, compressor will be on in heat pump prohibition zone.

- Other than heating
- Test run

● Heater selection control by outdoor temperature 2

Operation	Condition
Heater on	Heater is on as shown in following diagram of heating temperature.
Heater off	<ul style="list-style-type: none"> • Heater is off as shown in following diagram of heating temperature. • Other than heating mode • Error occurred • Forced thermostat off

- Temperature of heater on (Thon): Adjustable by function setting no. 62 (Operating temperature switching of external heaters).
- All control temperatures will shift by adjusting "Thon".
- Outdoor temperature zone boundary A and B: Adjustable by function setting no. 36 for outdoor unit.

• External heater output

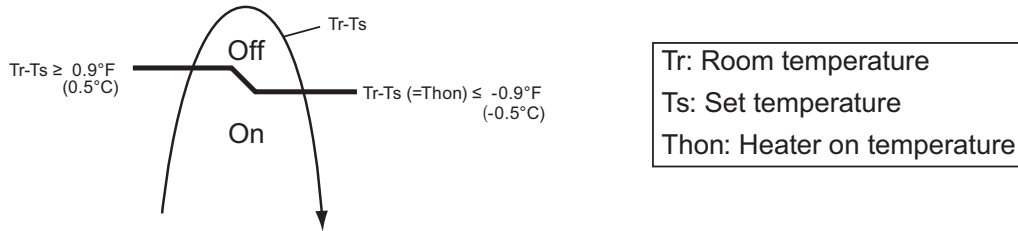

• Outdoor temperature zone

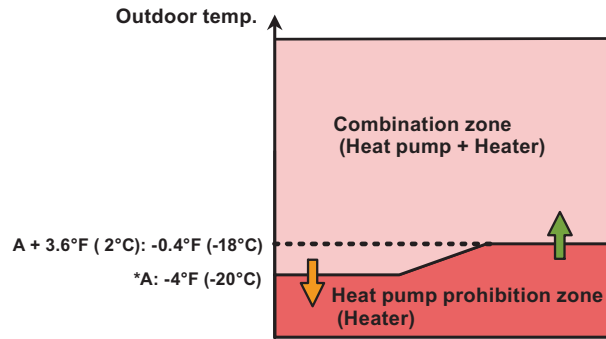

*Adjustable by function setting no. 66.

• Operation status

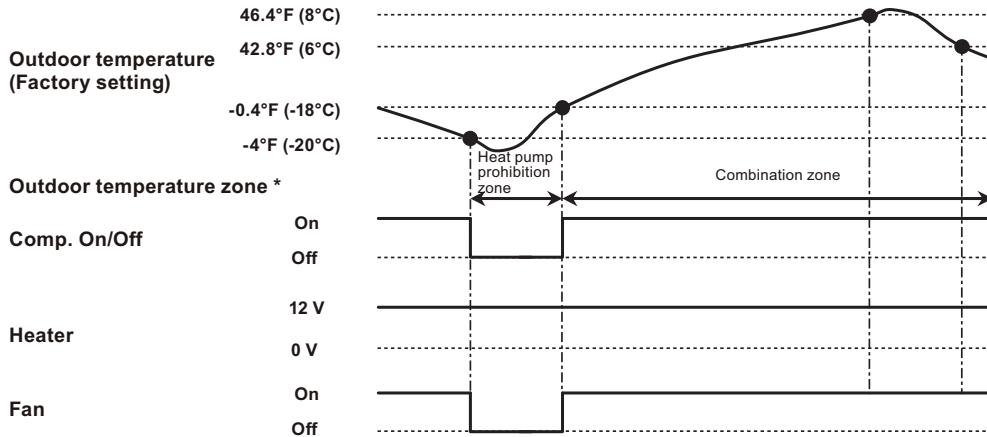

*The outdoor temperature zone transition from one to another will stay in that zone for minimum of 30 min.

NOTE: In following operations, compressor will be on in heat pump prohibition zone.

- Other than heating
- Test run

■ Heating thermostat on for humidifier

Situation	Indoor unit				
	Mode	Function setting	Rotary SW	External output	
		Heating thermostat on no. 60		Heating thermostat on	Indoor unit fan operation status
Example of individual connection	5	60-05	7	CN2	Not used
	6	60-06	8	CN312	
	7	60-07	9	CN311	
	8	60-08	A	CN310	

- **Example of individual connection**

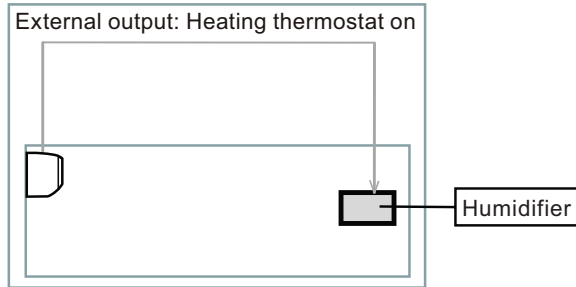

- **Operation status**

The heating thermostat output for CNB01 (1-2 or 1-3 or 1- or 1-5) will be on when comp. on or external heater on.

The heating thermostat output will be off when comp off and external heater off.

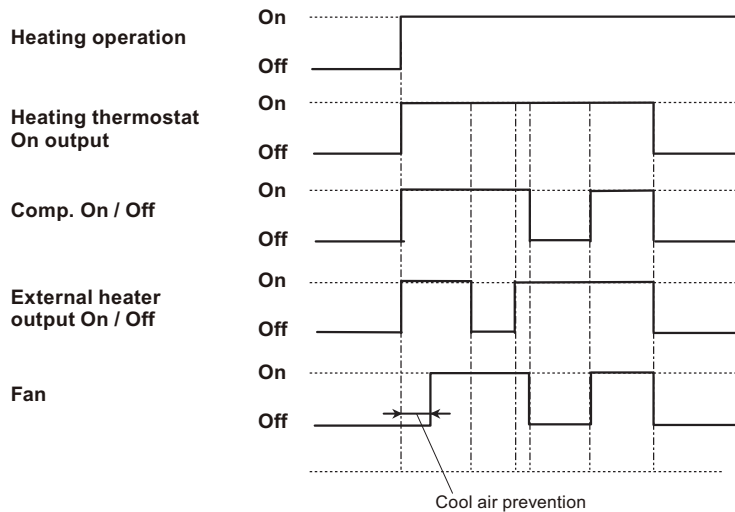

11. Function settings

To adjust the functions of this product according to the installation environment, various types of function settings are available.

NOTE: Incorrect settings can cause a product malfunction.

11-1. Function settings by using remote controller

Some function settings can be changed on the remote controller. After confirming the setting procedure and the content of each function setting, select appropriate functions for your installation environment.

■ Setting procedure by using wireless remote controller

The function number and the associated setting value are displayed on the LCD of the remote controller. Follow the instructions written in the local setup procedure supplied with the remote controller, and select appropriate setting according to the installation environment.

Before connecting the power supply of the indoor unit, reconfirm following items:

- Cover for the electrical enclosure on the outdoor unit is in place.
- There is no wiring mistake.
- Piping air tight test and vacuuming have been performed firmly.
- All the necessary wiring work for outdoor unit has been finished.

After reconfirming the items listed above, connect the power supply of the indoor unit.

NOTES:

- Settings will not be changed if invalid numbers or setting values are selected.
- When optional wired remote controller is used, refer to the installation manual enclosed with the remote controller.

Entering function setting mode:

While pressing the POWERFUL button and TEMP. (▲) button simultaneously, press the RESET button to enter the function setting mode.

Selecting the function number and setting value:

1. Press the TEMP. (▲) (▼) buttons to select the function number. To switch between the left and right digits, press the MIN. HEAT button.
2. Press the POWERFUL button to proceed to value setting. To return the function number selection, press the POWERFUL button again.
3. Press the TEMP. (▲) (▼) buttons to select the setting value. To switch between the left and right digits, press the MIN. HEAT button.
4. Press the MODE button once to send the function setting information. Confirm that you hear the beep sound.
5. Press the START/STOP button to fix the function setting. Confirm that you hear the beep sound.
6. Press the RESET button to end the function setting mode.
7. After completing the function setting, be sure to disconnect the power supply and then reconnect it.

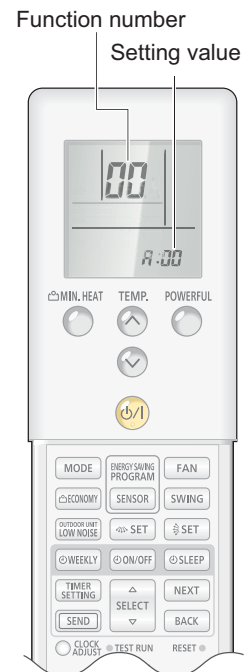

⚠ CAUTION

After disconnecting the power supply, wait 30 seconds or more before reconnecting it. The function setting will not become active unless the power supply is disconnected and then reconnected.

■ Contents of function setting

Each function setting listed in this section is adjustable in accordance with the installation environment.

NOTE: Setting will not be changed if invalid numbers or setting values are selected.

● Function setting list

	Function no.	Functions
1)	00	Remote controller address setting
2)	11	Filter sign
3)	30/31	Room temperature control for indoor unit sensor
4)	35/36	Room temperature control for wired remote controller sensor
5)	40	Auto restart
6)	42	Room temperature sensor switching
7)	44	Remote controller custom code
8)	46	External input control
9)	48	Room temperature sensor switching (Aux.)
10)	49	Indoor unit fan control for energy saving for cooling
11)	60	Switching functions for external output terminal
12)	66	Outdoor temperature zone boundary temperature A
13)	67	Outdoor temperature zone boundary temperature B
14)	94	Fixed operation mode switching
15)	96	Server room control

1) Remote controller address setting

NOTE: Because this setting is normally done automatically when 2-wire-type wired remote controller is installed, setting is unnecessary.

Multiple indoor units can be operated by using one wired remote controller.

Set the unit number of each indoor unit.

Function number	Setting value	Setting description	Factory setting
00	00	Unit no. 0	◆
	01	Unit no. 1	
	02	Unit no. 2	
	03	Unit no. 3	
	04	Unit no. 4	
	05	Unit no. 5	
	06	Unit no. 6	
	07	Unit no. 7	
	08	Unit no. 8	
	09	Unit no. 9	
	10	Unit no. 10	
	11	Unit no. 11	
	12	Unit no. 12	
	13	Unit no. 13	
	14	Unit no. 14	
	15	Unit no. 15	

NOTES:

- When connecting Polar 3-core wired remote controller, set the remote controller address in the order of 0, 1, 2,, and 15.
- When different type of indoor units (such as wall-mounted type and cassette type, cassette type and duct type, or other combinations) are connected using group control system, some functions may no longer be available.

2) Filter sign

Select appropriate intervals for displaying the filter sign on the indoor unit according to the estimated amount of dust in the air of the room.

If the indication is not required, select "No indication" (03).

Function number	Setting value	Setting description	Factory setting
11	00	Standard (400 hours)	
	01	Long interval (1,000 hours)	
	02	Short interval (200 hours)	
	03	No indication	◆

3) Room temperature control for indoor unit sensor

Depending on the installed environment, correction of the room temperature sensor may be required. Select the appropriate control setting according to the installed environment.

The temperature correction values show the difference from the Standard setting "00" (manufacturer's recommended value).

Function number	Setting value	Setting description	Factory setting		
30 (For cooling)	31 (For heating)	00	Standard setting	◆	
		01	No correction 0.0 °F (0.0 °C)		
		02	-1 °F (-0.5 °C)	More cooling Less heating	
		03	-2 °F (-1.0 °C)		
		04	-3 °F (-1.5 °C)		
		05	-4 °F (-2.0 °C)		
		06	-5 °F (-2.5 °C)		
		07	-6 °F (-3.0 °C)		
		08	-7 °F (-3.5 °C)		
		09	-8 °F (-4.0 °C)		
		10	+1 °F (+0.5 °C)	Less cooling More heating	
		11	+2 °F (+1.0 °C)		
		12	+3 °F (+1.5 °C)		
		13	+4 °F (+2.0 °C)		
		14	+5 °F (+2.5 °C)		
		15	+6 °F (+3.0 °C)		
		16	+7 °F (+3.5 °C)		
17	+8 °F (+4.0 °C)				

4) Room temperature control for wired remote controller sensor

Depending on the installed environment, correction of the wire remote temperature sensor may be required. Select the appropriate control setting according to the installed environment.

To change this setting, set Function 42 to Both "01".

Ensure that the Thermo Sensor icon is displayed on the remote controller screen.

Function number		Setting value	Setting description	Factory setting	
35 (For cooling)	36 (For heating)	00	Standard setting*	◆	
		01	No correction 0.0 °F (0.0 °C)		
		02	-1 °F (-0.5 °C)	More cooling Less heating	
		03	-2 °F (-1.0 °C)		
		04	-3 °F (-1.5 °C)		
		05	-4 °F (-2.0 °C)		
		06	-5 °F (-2.5 °C)		
		07	-6 °F (-3.0 °C)		
		08	-7 °F (-3.5 °C)		
		09	-8 °F (-4.0 °C)		
		10	+1 °F (+0.5 °C)	Less cooling More heating	
		11	+2 °F (+1.0 °C)		
		12	+3 °F (+1.5 °C)		
		13	+4 °F (+2.0 °C)		
		14	+5 °F (+2.5 °C)		
		15	+6 °F (+3.0 °C)		
		16	+7 °F (+3.5 °C)		
17	+8 °F (+4.0 °C)				

5) Auto restart

Enables or disables automatic restart after a power interruption.

Function number	Setting value	Setting description	Factory setting
40	00	Enable	◆
	01	Disable	

NOTE: Auto restart is an emergency function such as for power outage etc. Do not attempt to use this function in normal operation. Be sure to operate the unit by remote controller or external device.

6) Room temperature sensor switching

(Only for wired remote controller)

When using the wired remote controller temperature sensor, change the setting to "Both" (01).

Function number	Setting value	Setting description	Factory setting
42	00	Indoor unit	◆
	01	Both	

00: Sensor on the indoor unit is active.

01: Sensors on both indoor unit and wired remote controller are active.

NOTE: Remote controller sensor must be turned on by using the remote controller.

7) Remote controller custom code

(Only for wireless remote controller)

The indoor unit custom code can be changed. Select the appropriate custom code.

Function number	Setting value	Setting description	Factory setting
44	00	A	◆
	01	B	
	02	C	
	03	D	

8) External input control

"Operation/Stop" mode or "Forced stop" mode can be selected.

Function number	Setting value	Setting description	Factory setting
46	00	Operation/Stop mode 1	◆
	01	(Setting prohibited)	
	02	Forced stop mode	
	03	Operation/Stop mode 2	

9) Room temperature sensor switching (Aux.)

To use the temperature sensor on the wired remote controller only, change the setting to "Wired remote controller" (01).

This function will only work if the function setting 42 is set at "Both" (01).

When the setting value is set to "Both" (00), more suitable control of the room temperature is possible by setting function setting 30 and 31 too.

Function number	Setting value	Setting description	Factory setting
48	00	Both	◆
	01	Wired remote controller	

10) Indoor unit fan control for energy saving for cooling

Enables or disables the power-saving function by controlling the indoor unit fan rotation when the outdoor unit is stopped during cooling operation.

Function number	Setting value	Setting description	Factory setting
49	00	Disable	
	01	Enable	
	02	Remote controller	◆

00: When the outdoor unit is stopped, the indoor unit fan operates continuously following the setting on the remote controller.

01: When the outdoor unit is stopped, the indoor unit fan operates intermittently at a very low speed.

02: Enable or disable this function by remote controller setting.

NOTES:

- As the factory setting, this setting is initially .
- Set to "00" or "01" when connecting a remote controller that cannot set the Fan control for energy saving function or connecting a network converter.
To confirm if the remote controller has this setting, refer to the operating manual of each remote controller.

11) Switching functions for external output terminal

Functions of the external output terminal can be switched. For details, refer to “External input and output”.

Function number	Setting value	Setting description	Factory setting
60	00	Operation status	◆
	09	Error status	
	10	Indoor unit fan operation status	
	12	Set point attainment status	

12) Outdoor temperature zone boundary temperature A

Setting required if changing of the outdoor temperature setting for heat pump prohibition zone is required when heater selection control using outdoor temperature 1 and 2 are performed on the indoor unit. For details, refer to “External input and output”.

Function number	Setting value	Setting description	Factory setting
66	00	-4.0 °F (-20 °C)	◆
	01	-0.4 °F (-18 °C)	
	02	3.2 °F (-16 °C)	
	03	6.8 °F (-14 °C)	
	04	10.4 °F (-12 °C)	
	05	14.0 °F (-10 °C)	
	06	17.6 °F (-8 °C)	
	07	21.2 °F (-6 °C)	
	08	24.8 °F (-4 °C)	

13) Outdoor temperature zone boundary temperature B

Setting required if changing of the outdoor temperature setting for heat pump only zone is required when heater selection control using outdoor temperature 1 is performed on the indoor unit. For details, refer to “External input and output”.

Function number	Setting value	Setting description	Factory setting
67	00	42.8 °F (6 °C)	◆
	01	14.0 °F (-10 °C)	
	02	17.6 °F (-8 °C)	
	03	21.2 °F (-6 °C)	
	04	24.8 °F (-4 °C)	
	05	28.4 °F (-2 °C)	
	06	32.0 °F (0 °C)	
	07	35.6 °F (2 °C)	
	08	39.2 °F (4 °C)	
	09	42.8 °F (6 °C)	
	10	46.4 °F (8 °C)	
	11	50.0 °F (10 °C)	
	12	53.6 °F (12 °C)	
	13	57.2 °F (14 °C)	
	14	60.8 °F (16 °C)	
	15	64.4 °F (18 °C)	

14) Fixed operation mode switching

Sets the operation mode to heat pump, heating only, or cooling only.

Function number	Setting value	Setting description	Factory setting
94	00	Heat pump	◆
	01	Heating only	
	02	Cooling only	

15) Server room control

Switches between normal control and server room control.

NOTE: To use this function, address setting of the primary unit and secondary unit needs to be done.

Function number	Setting value	Setting description	Factory setting
96	00	Normal control	◆
	01	Server room control (Primary unit)	
	02	Server room control (Secondary unit)	

When performing server room control, mind the followings:

- Set to “01” on one of the 2 indoor units, and set to “02” on the other indoor unit.
- As for the function details and setup procedure, refer to [“Details of server room control”](#) on page 4.

11-2. Custom code setting for wireless remote controller

To interconnect the air conditioner and the wireless remote controller, assignment of the custom code for the wireless remote controller is required.

NOTE: Air conditioner cannot receive a signal if the air conditioner has not been set for the custom code.

When 2 or more air conditioners are installed in a room, and the remote controller is operating an air conditioner other than the one you wish to set, change the custom code of the remote controller to operate only the air conditioner you wish to set. (4 selections possible.)

Confirm the setting of the remote controller custom code and the function setting. If these do not match, the remote controller cannot be used to operate for the air conditioner.











1. Press the START/STOP button until only the clock is displayed on the remote controller display.
2. Press the MODE button for at least 5 seconds to display the current custom code. (Initially set to R .)
3. Press the TEMP. (\wedge) (\vee) buttons to change the custom code between R \rightarrow b \rightarrow c \rightarrow d . Match the code on the display to the air conditioner custom code. (Initially set to R .)
4. Press the MODE button again to return to the clock display. The custom code will be changed.

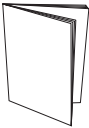

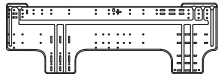
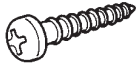
NOTES:

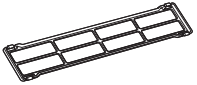

- If no button is pressed within 30 seconds after the custom code is displayed, the system returns to the original clock indicator. In this case, start again from step 1.
- The air conditioner custom code is set to R prior to shipment. To change the custom code, contact your retailer.
- If you do not know the assigned code for the air conditioner, try each of the custom code (R \rightarrow b \rightarrow c \rightarrow d) until you find the code which operates the air conditioner.

12. Accessories

Part name	Exterior	Q'ty	Part name	Exterior	Q'ty
Operating manual		1	Drain hose insulation		1
Installation manual		1	Cloth tape		1
Wall hook bracket		1	Tapping screw (large), M4 x 25 mm		8
Remote controller		1	Tapping screw (small), M3 x 12 mm		2
Battery		2	Air cleaning filter		2
Remote controller holder		1	Air cleaning filter frame		2

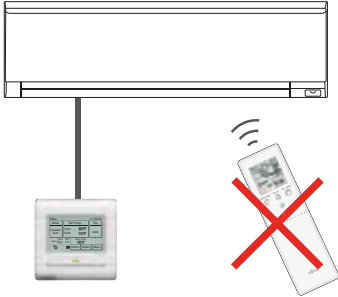
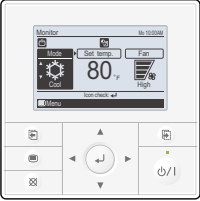
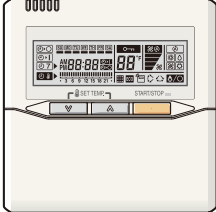

13. Optional parts

13-1. Controllers

Exterior	Part name	Model name	Summary
	Wired remote controller		<p>Easy finger touch operation with LCD panel. Backlit LCD enables easy operation in a dark room. Wire type: Non-polar 2-wire</p> <p>NOTE: When this remote controller is connected, wireless remote controller cannot be used.</p> 
	Wired remote controller	UXRVNUM	<p>Large and full-dot liquid crystal screen, wide and large keys easy to press, user-intuitive arrow key. Wire type: Polar 3-wire</p>
	Wired remote controller	UXRNUM	<p>Room temperature can be controlled by detecting the temperature accurately with built-in thermo sensor. Wire type: Polar 3-wire</p>
	Simple remote controller	UXRSNUM	<p>Compact remote controller concentrates on the basic functions such as Start/Stop, fan control, temperature setting, and operation mode. Wire type: Polar 3-wire</p>

NOTE: Available functions may differ by the remote controller. For details, refer to the operation manual.

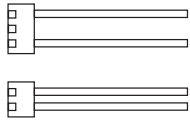
13-2. Others

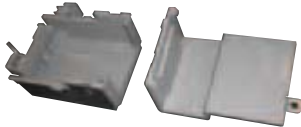
Exterior	Part name	Model name	Summary
 The image shows two sets of external connect kits. Each set consists of a small rectangular connector with four pins on one side and a corresponding four-pin socket on the other, connected by a thin cable.	External connect kit	RXXWZX	Use to connect with various peripheral devices and air conditioner PCB.
 The image shows a green printed circuit board (PCB) with various electronic components, including integrated circuits, resistors, and connectors, used for external input and output.	External input and output PCB		Use to connect with external devices and air conditioner PCB.
 The image shows a white plastic box, which is the enclosure for the external input and output PCB. It is shown in two views: one closed and one open, revealing the internal mounting area.	External input and output PCB box		For installing the External input and output PCB.

Part 2. OUTDOOR UNIT

**SINGLE TYPE:
UOSH30AHXHJ**

1. Specifications

Type				Inverter heat pump
Model name				UOSH30AHXHJ
Power supply				208/230 V ~ 60 Hz
Available voltage range				187—253 V
Starting current				18.7
Fan	Airflow rate	Cooling	CFM (m ³ /h)	4,032 (6,850)
		Heating		4,032 (6,850)
	Type x Q'ty	Propeller fan x 2		
Motor output			W	100 x 2
Sound pressure level *1	Cooling		dB (A)	53
	Heating			54
Heat exchanger type	Dimensions (H x W x D)		in	49-10/16 x 35-7/16 x 1-7/16
			mm	1,260 x 900 x 36.4
	Fin pitch		FPI	1.3
	Rows x Stages			2 x 60
	Pipe type			Copper
	Fin type		Type (Material) Surface treatment	Corrugate (Aluminum) Hydrophilic coating (Blue fin)
Compressor	Type x Q'ty			Twin rotary x 1
	Motor output			W
Refrigerant	Type			R410A
	Charge	lb oz		6 lb 12 oz
g		3,050		
Refrigerant oil	Type			POE (VG74)
	Amount	in ³ (cm ³)		94.5 (1,550)
Enclosure	Material			Steel sheet
	Color			Beige Approximate color of MUNSELL 10YR7.5/1.0
Dimensions (H x W x D)	Net	in		50-13/16 x 35-7/16 x 13
		mm		1,290 x 900 x 330
	Gross	in		57-1/2 x 41-5/16 x 17-1/2
		mm		1,460 x 1,050 x 445
Weight	Net		lb (kg)	205 (93)
	Gross			227 (103)
Connection pipe	Size	Liquid	in (mm)	Ø 3/8 (Ø 9.52)
		Gas		Ø 5/8 (Ø 15.88)
	Method			Flare
	Pre-charge length			65 (20)
	Max. length			246 (75)
	Max. height difference			98 (30)
Operation range	Cooling		°F (°C)	-5 to 115 (-20 to 46)
	Heating			-15 to 75 (-26 to 24)
Drain hose	Material			LDPE
	Size			mm
				Ø 13.0 (I. D.), Ø 16.0 to Ø 16.7 (O. D.)
NOTES:				
<ul style="list-style-type: none"> • Specifications are based on the following conditions: <ul style="list-style-type: none"> – Cooling: Indoor temperature of 80 °FDB (26.67 °CDB) / 67 °FWB (19.44 °CWB), and outdoor temperature of 95 °FDB (35 °CDB) / 75 °FWB (23.9 °CWB). – Heating: Indoor temperature of 70 °FDB (21.11 °CDB) / 59 °FWB (15 °CWB), and outdoor temperature of 47 °FDB (8.33 °CDB) / 43 °FWB (6.11 °CWB). – Pipe length: 24 ft 6 in (7.5 m), Height difference: 0 ft (0 m). (Between outdoor unit and indoor unit.) • Protective function might work when using it outside the operation range. • *1: Sound pressure level <ul style="list-style-type: none"> – Measured values in manufacturer's anechoic chamber. – Because of the surrounding sound environment, the sound levels measured in actual installation conditions might be higher than the specified values here. 				

2. Dimensions

2-1. Model: UOSH30AHXHJ

Unit: in (mm)

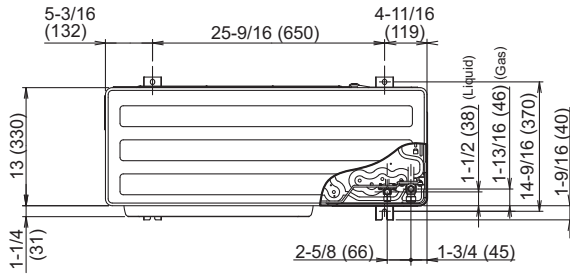

Top view

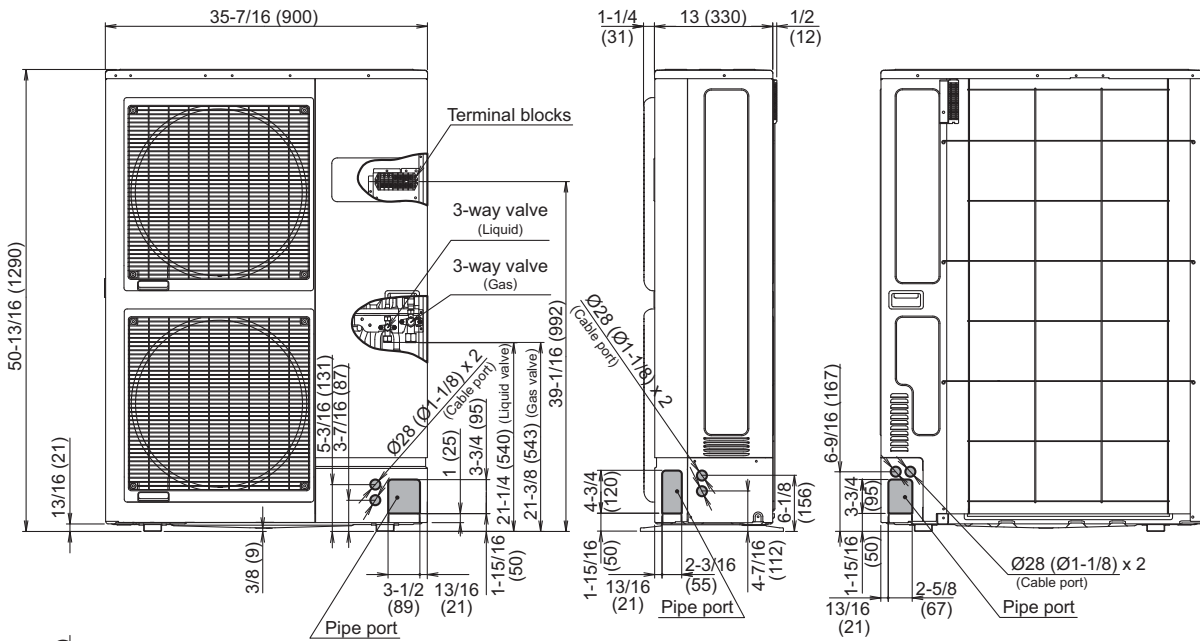

Front view

Side view

Rear view

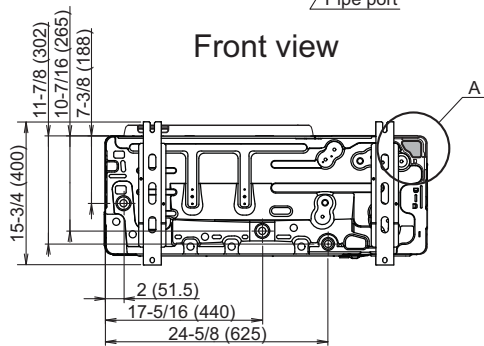

Bottom view

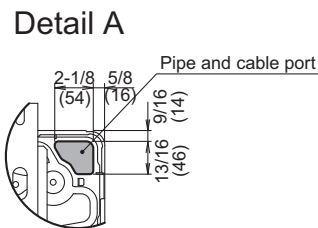

Detail A

3. Installation space

3-1. Model: UOSH30AHXHJ

■ Space requirement

Provide sufficient installation space for product safety.

● Single outdoor unit installation

- When the upper space is open:

Unit: in (mm)

When there are obstacles at the rear only.

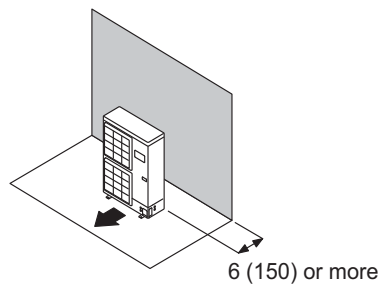

When there are obstacles at the rear and sides.

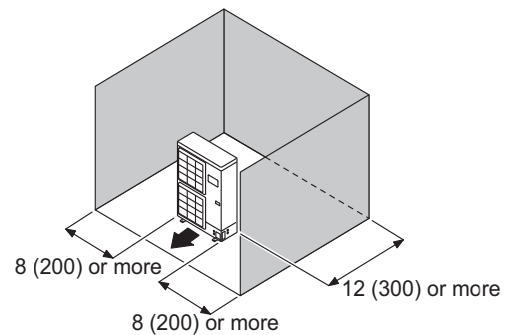

When there are obstacles at the front only.

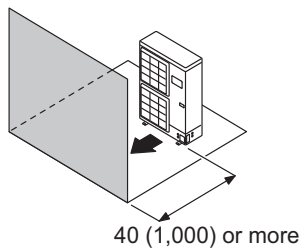

When there are obstacles at the front and rear.

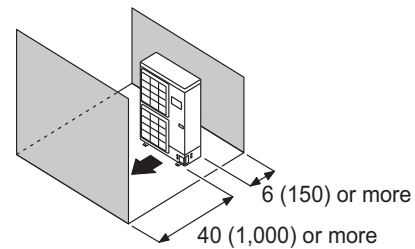

- When there is an obstruction in the upper space:

Unit: in (mm)

When there are obstacles at the rear and above.

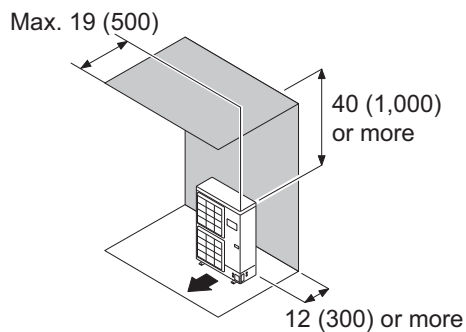

When there are obstacles at the rear, sides, and above.

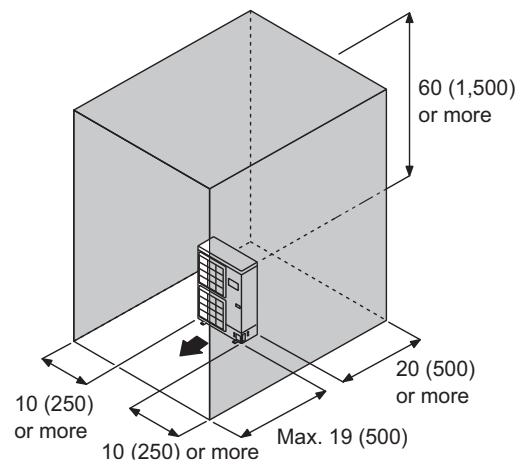

● Multiple outdoor unit installation

- When the upper space is open:

Unit: in (mm)

When there are obstacles at the rear only.

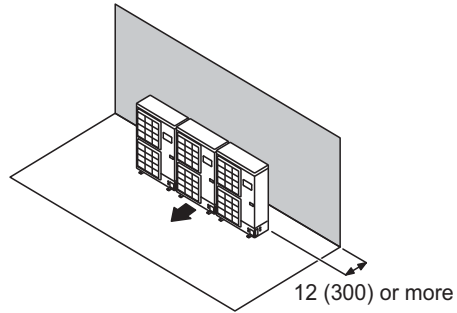

When there are obstacles at the front only.

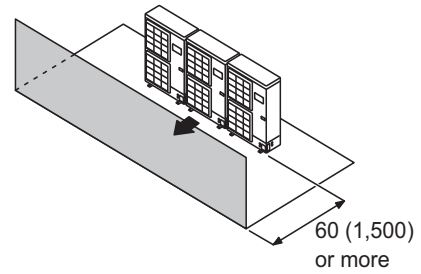

When there are obstacles at the front and rear.

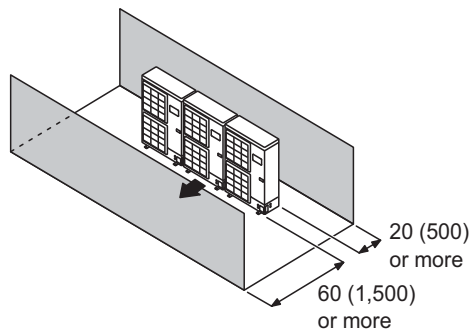

- When there is an obstruction in the upper space:

Unit: in (mm)

When there are obstacles at the rear and above.

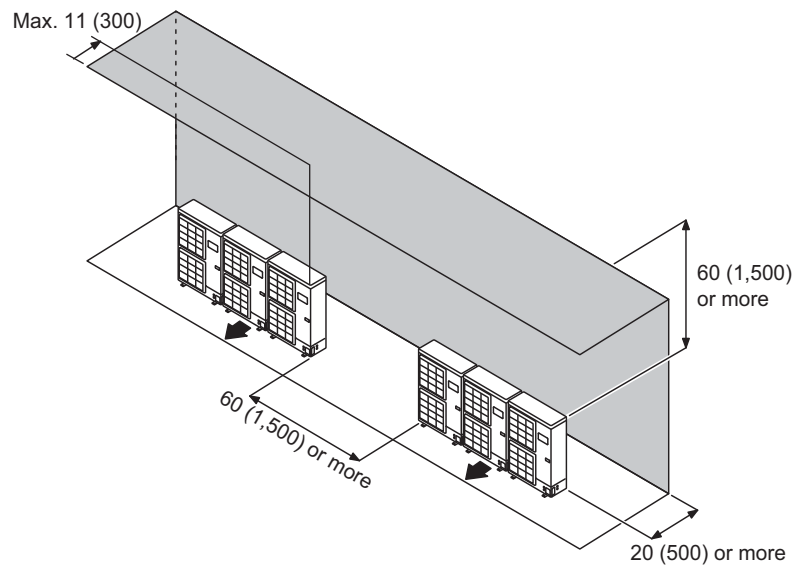

● Outdoor unit installation in multi-row

Unit: in (mm)

Single parallel unit arrangement

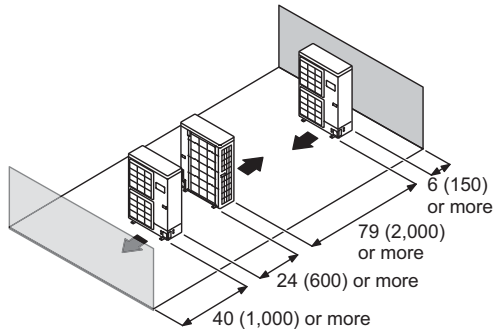

Multiple parallel unit arrangement

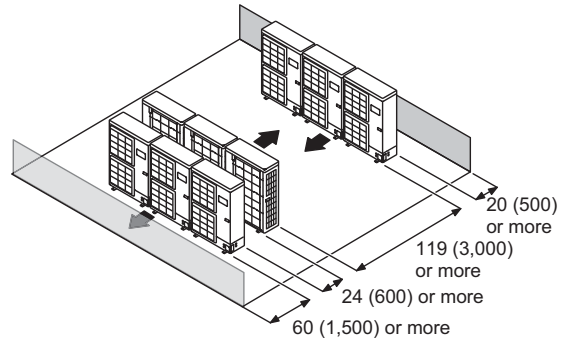

NOTES:

- If the space is larger than stated above, the condition will be the same as when there is no obstacle.
- Height above the floor level should be 2 in (50 mm) or more.
- When installing the outdoor unit, be sure to open the front and left side to obtain better operation efficiency.

⚠ CAUTION

- Do not install the outdoor unit in two-stage where the drain water could freeze. Otherwise the drainage from the upper unit may form ice and cause a malfunction of the lower unit.
- When the outdoor temperature is 32 °F (0 °C) or less, do not use the accessory drain pipe and drain cap. If the drain pipe and drain cap are used, the drain water in the pipe may freeze in extremely cold climate. (For reverse cycle model only.)
- In area with heavy snowfall, if the inlet and outlet of the outdoor unit is blocked with snow, it might become difficult to get warm, and it is likely to cause product malfunction. Construct a canopy and a pedestal, or place the unit on a high stand that is locally installed.

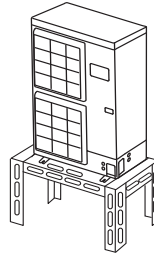

4. Refrigerant circuit

4-1. Model: UOSH30AHXHJ

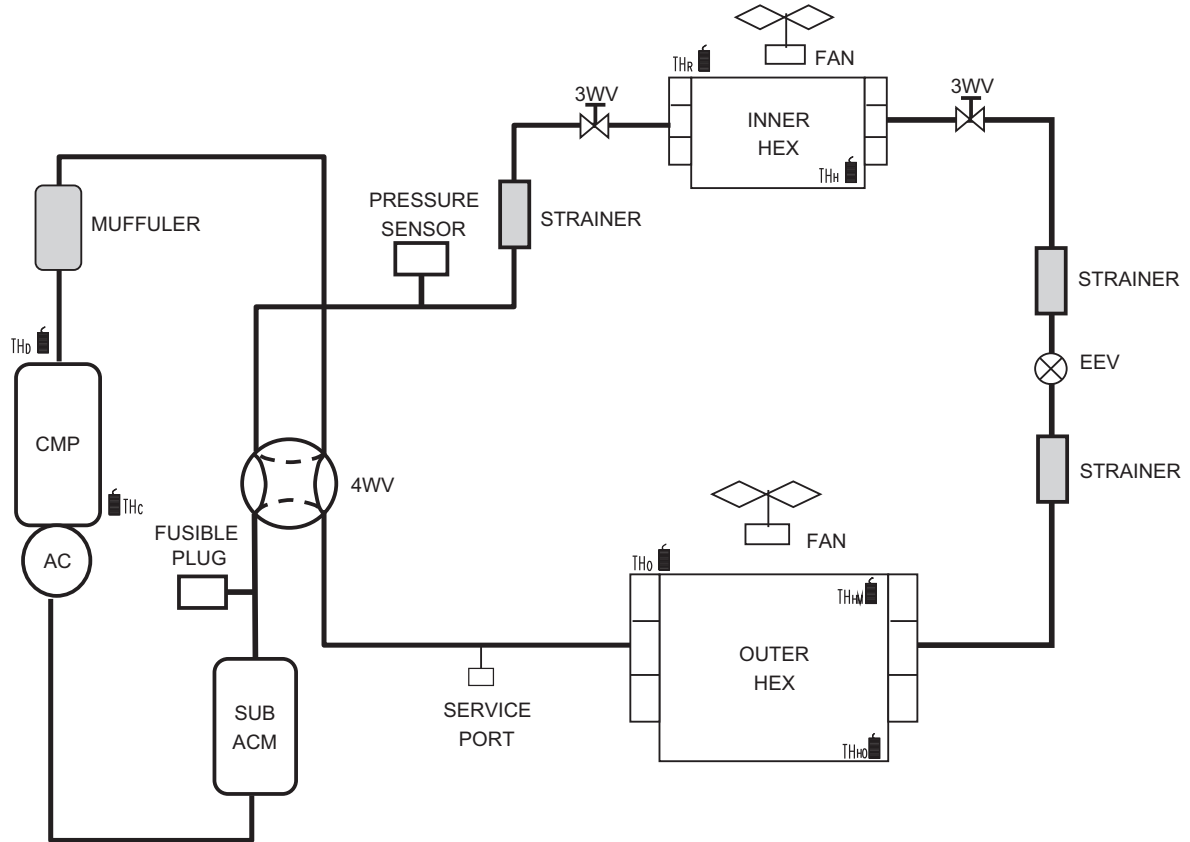

TH_c: Thermistor(Compressor Temp.)
 TH_d: Thermistor(Discharge Temp.)
 TH_m: Thermistor(Heat Exchanger Med Temp.)
 TH_o: Thermistor(Heat Exchanger Out Temp.)
 TH_o: Thermistor(Outdoor Temp.)

TH_r: Thermistor(Room Temp.)
 TH_m: Thermistor(Heat Exchanger Temp.)

5. Wiring diagrams

5-1. Model: UOSH30AHXHJ

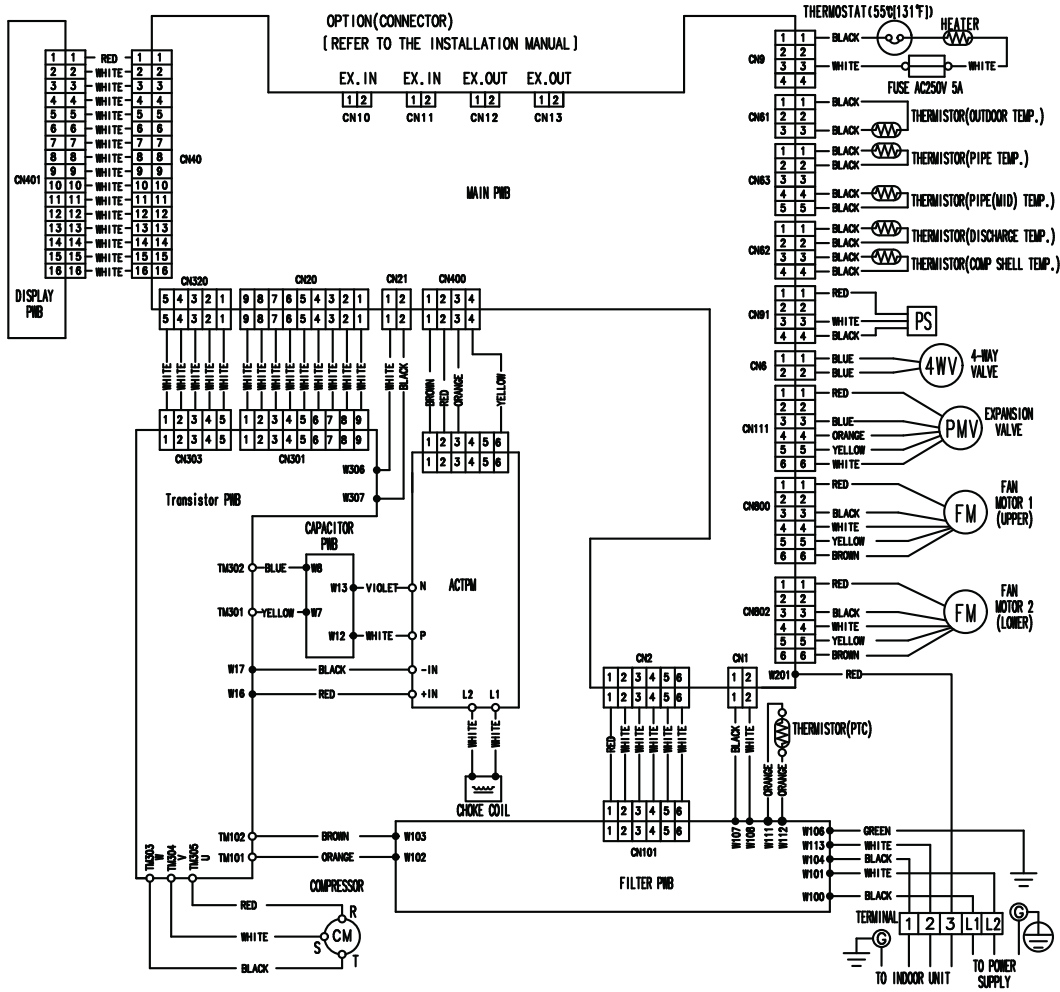

6. Capacity compensation rate for pipe length and height difference

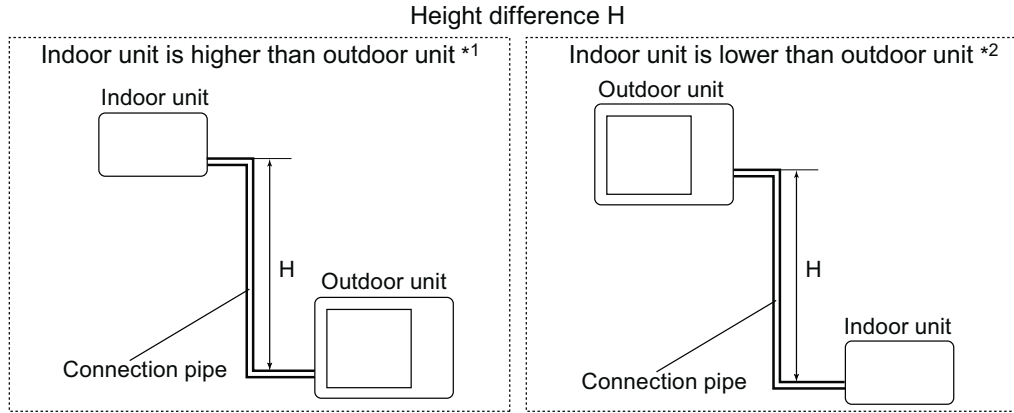

6-1. Model: UOSH30AHXHJ

NOTE: Values mentioned in the table are calculated based on the maximum capacity.

COOLING		Pipe length										
		m	5	7.5	10	20	30	40	50	60	75	
		ft	16	24	32	65	98	131	164	196	246	
Height difference H	Indoor unit is higher than outdoor unit *1	30	98	-	-	-	-	0.912	0.893	0.875	0.857	0.823
		20	65	-	-	-	0.945	0.927	0.908	0.890	0.872	0.837
		10	32	-	-	0.980	0.961	0.942	0.923	0.905	0.886	0.851
		7.5	24	-	0.988	0.984	0.965	0.946	0.927	0.908	0.890	0.854
		5	16	0.992	0.992	0.988	0.969	0.950	0.931	0.912	0.893	0.858
		0	0	1.000	1.000	0.996	0.977	0.958	0.939	0.920	0.901	0.865
	Indoor unit is lower than outdoor unit *2	-5	-16	1.000	1.000	0.996	0.977	0.958	0.939	0.920	0.901	0.865
		-7.5	-24	-	1.000	0.996	0.977	0.958	0.939	0.920	0.901	0.865
		-10	-32	-	-	0.996	0.977	0.958	0.939	0.920	0.901	0.865
		-20	-65	-	-	-	0.977	0.958	0.939	0.920	0.901	0.865
-30		-98	-	-	-	-	0.958	0.939	0.920	0.901	0.865	

HEATING		Pipe length										
		m	5	7.5	10	20	30	40	50	60	75	
		ft	16	24	32	65	98	131	164	196	246	
Height difference H	Indoor unit is higher than outdoor unit *1	30	98	-	-	-	-	0.978	0.968	0.958	0.948	0.935
		20	65	-	-	-	0.988	0.978	0.968	0.958	0.948	0.935
		10	32	-	-	0.998	0.988	0.978	0.968	0.958	0.948	0.935
		7.5	24	-	1.000	0.998	0.988	0.978	0.968	0.958	0.948	0.935
		5	16	1.000	1.000	0.998	0.988	0.978	0.968	0.958	0.948	0.935
		0	0	1.000	1.000	0.998	0.988	0.978	0.968	0.958	0.948	0.935
	Indoor unit is lower than outdoor unit *2	-5	-16	0.995	0.995	0.993	0.983	0.973	0.963	0.953	0.943	0.930
		-7.5	-24	-	0.993	0.990	0.980	0.970	0.960	0.950	0.940	0.928
		-10	-32	-	-	0.988	0.978	0.968	0.958	0.948	0.938	0.926
		-20	-65	-	-	-	0.968	0.958	0.948	0.938	0.929	0.916
-30		-98	-	-	-	-	0.948	0.939	0.929	0.919	0.907	

7. Additional charge calculation

7-1. Model: UOSH30AHXHJ

Refrigerant type		R410A
Refrigerant amount	lb oz	6 lb 12 oz
	g	3,050

■ Refrigerant charge

Total pipe length	ft	65 or less	98	131	164	246 (Max.)	0.43 oz/ft (40 g/m)
	m	20 or less	30	40	50	75 (Max.)	
Additional charge	oz	0	14.1	28.2	42.3	77.6	
	g	0	400	800	1,200	2,200	

8. Airflow

8-1. Model: UOSH30AHXHJ

● Cooling

m ³ /h	6,850
l/s	1,903
CFM	4,032

● Heating

m ³ /h	6,850
l/s	1,903
CFM	4,032

9. Operation noise (sound pressure)

9-1. Noise level curve

■ Model: UOSH30AHXHJ

● Cooling

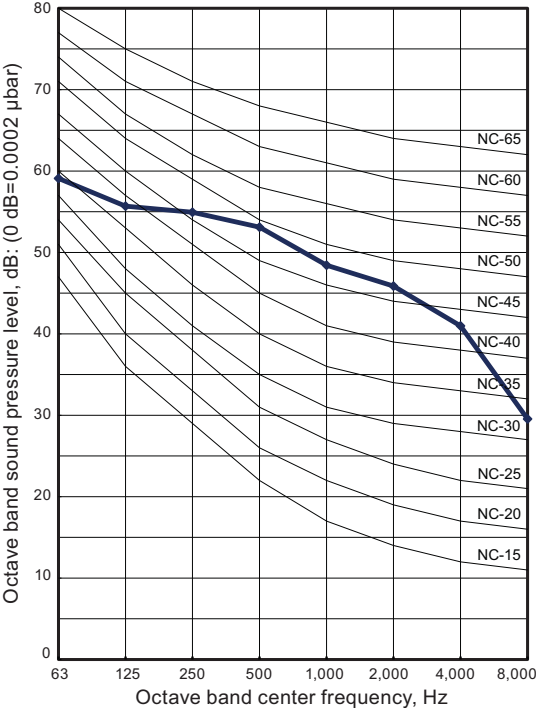

● Heating

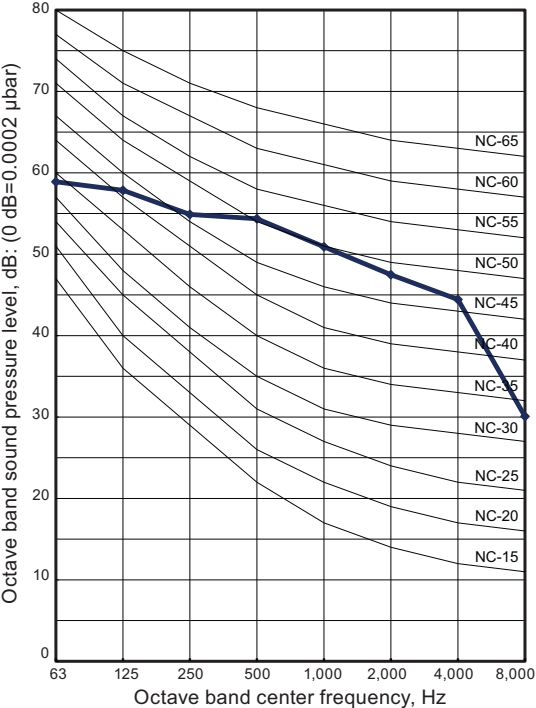

9-2. Sound level check point

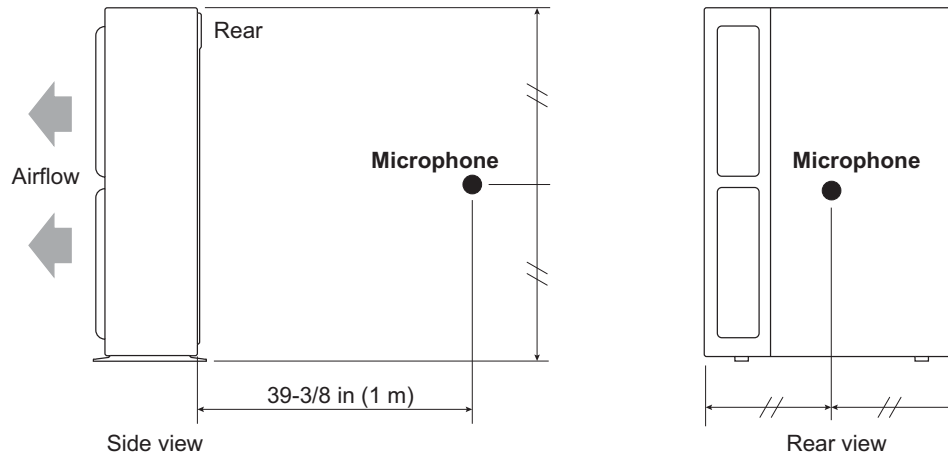

NOTE: Detailed shape of the actual outdoor unit might be slightly different from the one illustrated above.

10. Electrical characteristics

Model name			UIWH30AVFJ
Power supply	Voltage	V	208/230
	Frequency	Hz	60
MCA *1		A	25.6
Starting current		A	18.7
Wiring spec. *2	MAX. CKT. BKR *3	A	30
	Power cable	AWG	10
	Connection cable *4	AWG	14
	Limited wiring length	ft (m)	249 (76)

*1: Minimum Circuit Ampacity (Calculation based on UL1995)

*2: Selected sample based on Japan Electrotechnical Standards and Codes Committee E0005. As the regulations of wire size and circuit breaker differ in each country or region, select appropriate devices complied to the regional standard.

*3: Maximum Circuit Breaker

*4: Limit voltage drop to less than 2%. If voltage drop is 2% or more, increase cable conductor size.

11. Safety devices

Type of protection	Protection form		Model
			UOSH30AHXHJ
Circuit protection	Current fuse (Near the terminal)		250 V, 25 A
	Current fuse (Filter PCB)		250 V, 10 A
	Current fuse (Main PCB)		250 V, 5 A
	Current fuse (Out of PCB)		250 V, 3.15 A
Fan motor protection	Thermistor protection	Activate	122±9 °C Fan motor stop
		Reset	116 ⁺¹⁰ ₋₉ °C Fan motor restart
Compressor protection	Terminal protection program (Compressor temp.)	Activate	108 °C Compressor stop
		Reset	After 40 minutes Compressor restart
	Thermal protection program (Discharge temp.)	Activate	110°C Compressor stop
		Reset	After 7 minutes Compressor restart
High pressure protection	Pressure switch	Activate	4.2±0.1 MPa Compressor stop
		Reset	3.2±0.15 MPa Compressor restart
High pressure protection	Pressure switch	Activate	4.2±0.1 MPa Compressor stop
		Reset	3.2±0.15 MPa Compressor restart
Low pressure protection	Pressure sensor	Activate	4.2±0.1 MPa Compressor stop
		Reset	3.2±0.15 MPa Compressor restart

12. External input and output

With using external input and output functions, this product can be operated inter-connectedly with an external device.

Connector	Input	Output	Remarks
CN10	Low noise mode	—	See external input/output settings for details.
CN11	Peak cut mode	—	
CN12	—	Error status	
CN13	—	Compressor status	

12-1. External input

With using external input function, on/off status of “Low noise mode” and “Peak cut mode” can be specified by the external signal.

■ Low noise mode

In following condition, the operating noise of the outdoor unit reduces comparing from the one in normal operating condition:

The air conditioner is set to the “Low noise mode” when closing the contact input of a commercial timer or on/off switch to a connector on the control PCB of the outdoor unit

NOTE: Product performance may drop depending on some conditions such as the outdoor temperature.

● Circuit diagram example

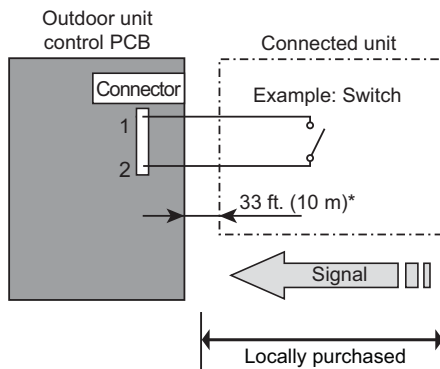

- Contact capacity: DC 24 V or more, 10 mA or more.
- *: Make the distance from the PCB to the connected unit within 33 ft (10 m).
- Construct a circuit as shown in this figure with using optional parts mentioned below.
- Input signal: On in “Low noise mode”
- Input signal: Off in normal operation
- To set the level of “Low noise mode”, refer to “[Low noise mode](#)” on page 80.

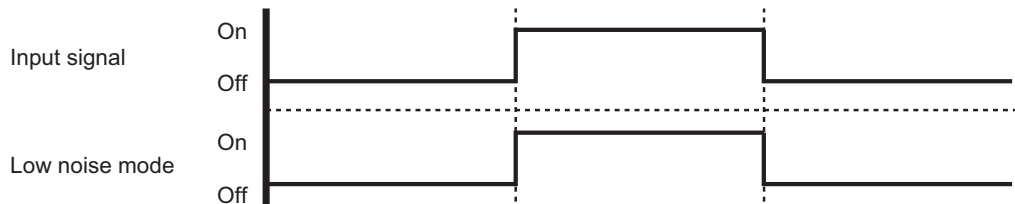

● Optional part

Part name	Model name	Exterior
External connect kit	RXXWZXZ3	

■ Peak cut mode

By performing following on-site work, operation that suppresses the current value can be enabled: The air conditioner is set to the “Peak cut mode” when closing the contact input of a commercial timer or on/off switch to a connector on the control PCB of the outdoor unit.

● Circuit diagram example

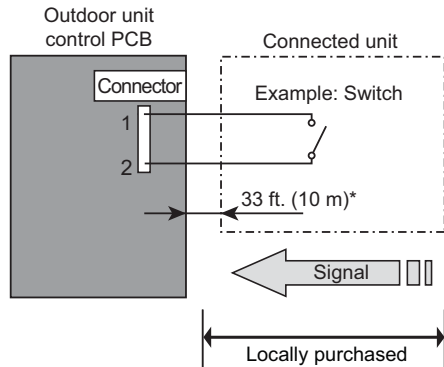

- Contact capacity: DC 24 V or more, 10 mA or more.
- *: Make the distance from the PCB to the connected unit within 33 ft (10 m).
- Construct a circuit as shown in this figure with using optional parts mentioned below.
- Input signal: On in “Peak cut mode”
- Input signal: Off in normal operation
- To set the level of “Peak cut mode”, refer to [“Peak cut mode”](#) on page 82.

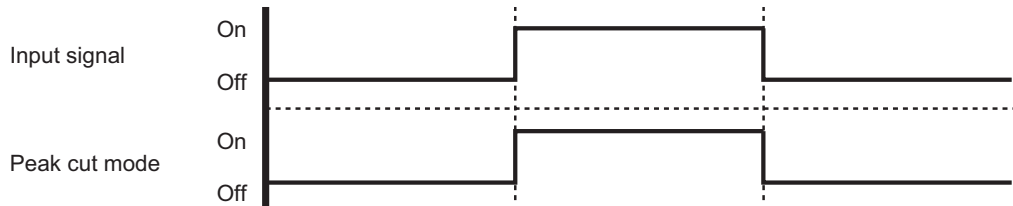

● Optional part

Part name	Model name	Exterior
External connect kit	RXXWZXZ3	

12-2. External output

With using external output function, some status signals are transmitted to the control PCB, and the related LED lamp indicates the status of this product.

■ Error status output

● Circuit diagram example

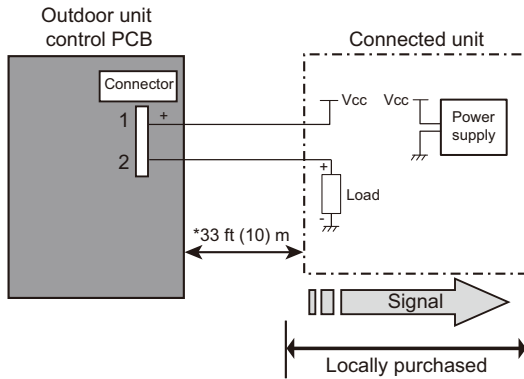

- 1: Power supply
Voltage (Vcc): DC 24 V or less
- 2: Load
DC 500 mA or less
- *: Make the distance from the PCB to the connected unit within 33 ft (10 m).

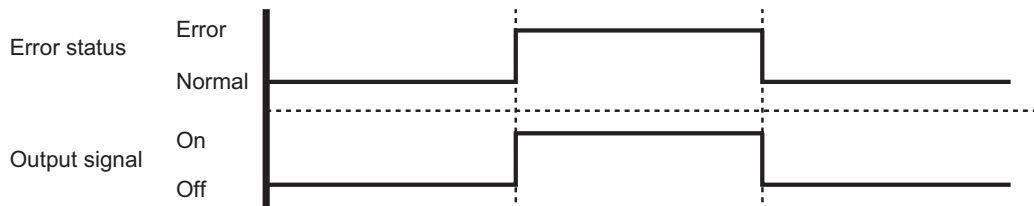

● Optional part

Part name	Model name	Exterior
External connect kit	RXXWZXZ3	

■ Compressor status output

● Circuit diagram example

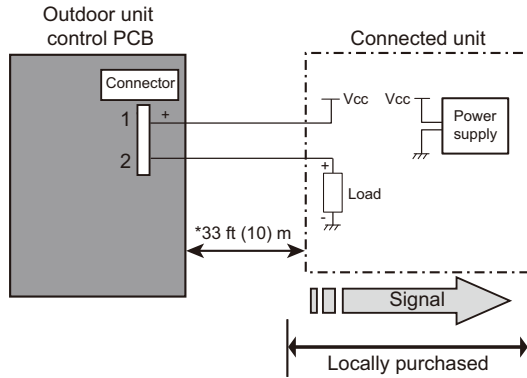

- 1: Power supply
Voltage (Vcc): DC 24 V or less
- 2: Load
DC 500 mA or less
- *: Make the distance from the PCB to the connected unit within 33 ft (10 m).

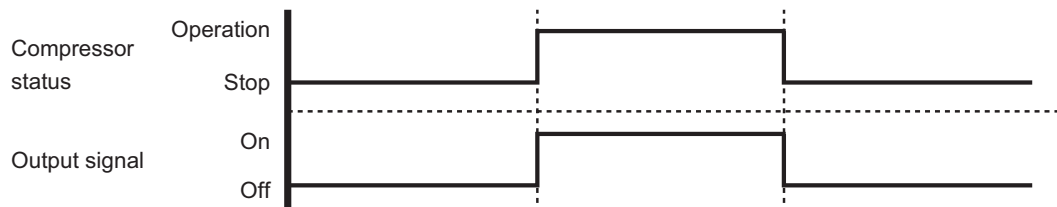

● Optional part

Part name	Model name	Exterior
External connect kit	RXXWZXZ3	

13. Function settings

Perform appropriate function setting locally according to the installation environment.

NOTE: Incorrect settings can cause a product malfunction.

⚠ CAUTION

- Before setting up the switch buttons, discharge the static electricity from your body.
 - Never touch the terminals or the patterns on the parts that are mounted on the PCB.
-

13-1. Local setting switch buttons

■ Control PCB and switch buttons location

Control PCB of the outdoor unit is located as shown in the following figure.

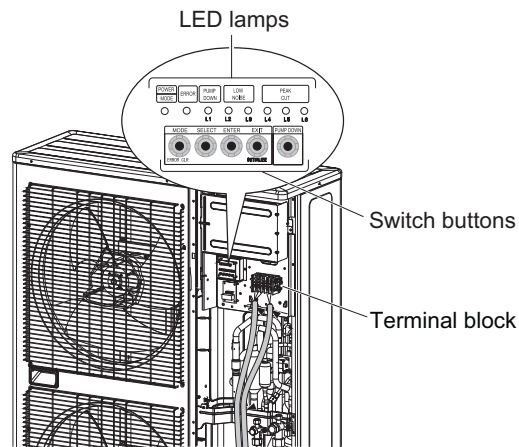

■ Switch buttons and the functions

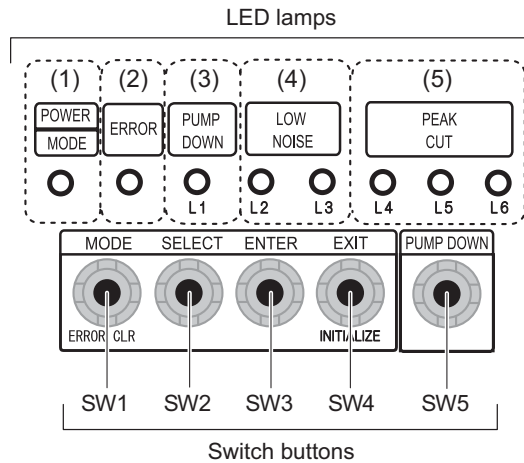

LED lamp			Function or operation method
(1)	POWER/MODE	Green	Lights on while power on. Local setting in outdoor unit or error code is displayed with blink.
(2)	ERROR	Red	Blinks during error operation.
(3)	PUMP DOWN (L1)	Orange	Lights on during pump down operation.
(4)	LOW NOISE MODE (L2 and L3)	Orange	Lights on during "Low noise mode" when local setting is activated. (Lighting pattern of L2 and L3 indicates low noise level.)
(5)	PEAK CUT MODE (L4, L5, and L6)	Orange	Lights on during "Peak cut mode" when local setting is activated. (Lighting pattern of L4, L5, and L6 indicates peak cut level.)

Switch button		Function or operation method
SW1	MODE	Switches between "Local setting" and "Error code display".
SW2	SELECT	Switches between the individual "Local settings" and the "Error code displays".
SW3	ENTER	Switches between the individual "Local settings" and the "Error code displays".
SW4	EXIT	Returns to "Operation status display".
SW5	PUMP DOWN	Starts the pump down operation.

13-2. Local setting procedure

NOTE: Before performing the function setting, be sure to stop the operation of the air conditioner.

■ Low noise mode

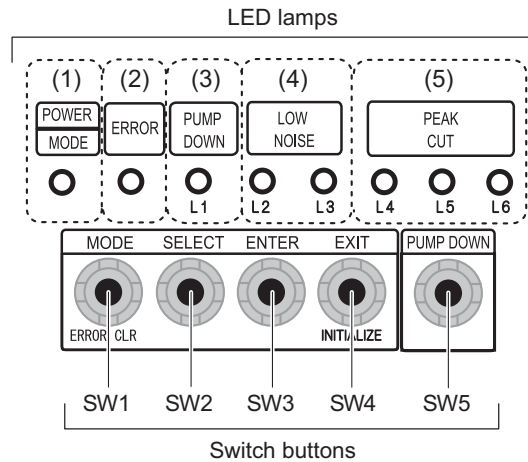

1. Press the MODE switch button (SW1) for 3 seconds or more to switch to "Local setting mode".
2. After confirming the LED lamp of POWER/MODE blinks 9 times, press the ENTER switch button (SW3).

POWER MODE	ERROR	PUMP DOWN (L1)	LOW NOISE (L2) (L3)	PEAK CUT (L4) (L5) (L6)		
Blinks (9 times)	○	○	○ ○	○	○	○

Sign "○": Lights off

3. Press the SELECT switch button (SW2), and adjust the LED lamp as shown below. Then the LED lamp indicates the current setting.

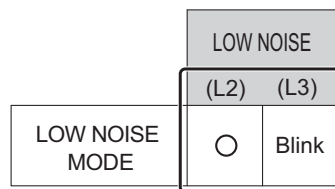

4. Press the ENTER switch button (SW3).

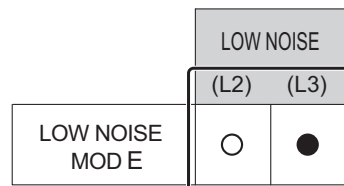

Sign "●": Lights on

5. Press the SELECT switch button (SW2), and adjust the LED lamps as shown below.

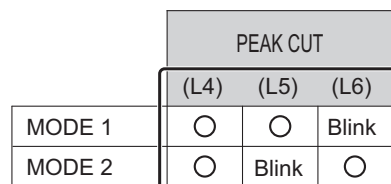

6. Press the ENTER switch button (SW3) and fix it.

PEAK CUT			
	(L4)	(L5)	(L6)
MODE 1	<input type="radio"/>	<input type="radio"/>	<input checked="" type="radio"/>
MODE 2	<input type="radio"/>	<input checked="" type="radio"/>	<input type="radio"/>

7. To return to “Operating status display (Normal operation)”, press the EXIT switch button (SW4).

In case of missing how many times you pressed the SELECT and ENTER switch buttons:

1. To return to “Operation status display (Normal operation)”, press the EXIT switch button once.
2. Restart from the beginning of setting procedure.

NOTE: In case of missing how many times you pressed the SELECT and ENTER switch buttons, you must redo the setting procedure. Return to “Operation status display (Normal operation)” by pressing the EXIT switch button once, and restart from the beginning of the setting procedure.

■ Peak cut mode

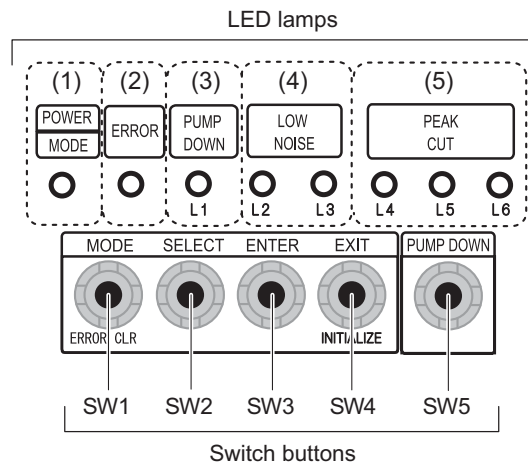

1. Press the MODE switch button (SW1) for 3 seconds or more to switch to “Local setting mode”.
2. After confirming the LED lamp of POWER/MODE blinks 9 times, press the ENTER switch button (SW3).

POWER MODE	ERROR	PUMP DOWN (L1)	LOW NOISE (L2) (L3)	PEAK CUT (L4) (L5) (L6)		
Blinks (9 times)	○	○	○	○	○	○

Sign “○”: Lights off

3. Press the SELECT switch button (SW2), and adjust the LED lamp as shown below. Then the LED lamp indicates the current setting.

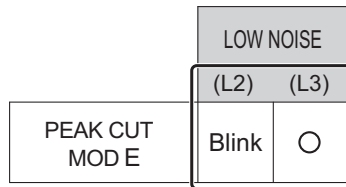

4. Press the ENTER switch button (SW3).

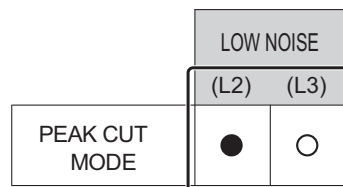

Sign “●”: Lights on

5. Press the SELECT switch button (SW2), and adjust the LED lamps as shown below.

	PEAK CUT (L4) (L5) (L6)		
100 % of rated input ratio	○	○	Blink
75 % of rated input ratio	○	Blink	○
50 % of rated input ratio	○	Blink	Blink
0 % of rated input ratio	Blink	○	○



6. Press the ENTER switch button (SW3) and fix it.

	PEAK CUT		
	(L4)	(L5)	(L6)
100 % of rated input ratio	<input type="radio"/>	<input type="radio"/>	<input checked="" type="radio"/>
75 % of rated input ratio	<input type="radio"/>	<input checked="" type="radio"/>	<input type="radio"/>
50 % of rated input ratio	<input type="radio"/>	<input checked="" type="radio"/>	<input checked="" type="radio"/>
0 % of rated input ratio	<input checked="" type="radio"/>	<input type="radio"/>	<input type="radio"/>

7. To return to “Operating status display (Normal operation)”, press the EXIT switch button (SW4).

NOTE: When pressed number is lost during setting, you must redo the setting procedure. Return to “Operation status display (Normal operation)” by pressing the EXIT switch button once, and restart from the beginning of the setting procedure.

14. Accessories

Part name	Exterior	Q'ty	Part name	Exterior	Q'ty
Installation manual		1	Conduit plate		1

15. Optional parts

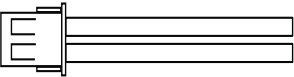
Exterior	Part name	Model name	Summary
	External connect kit	RXXWZXZ3	Use to operate the external input and output functions of outdoor unit.